

-07P2

Montageanweisung / Installation instructions / Instruction de montage / Istruzioni di montaggio
montagehandleiding / Instrukcja montażu / Montaj talimatlar / Osszeselési útmutató / Nàvod k montáži /
Nàvod na montaž / Instrucțiune de montaj / инструкции по сборке / Montaj talimatina / Monteringsanvisningar/
Upute za montažu / Instrucciones de Montaje / Navodila za montažo

ROMANE

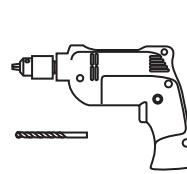
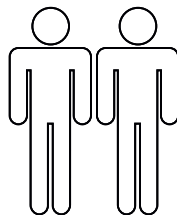
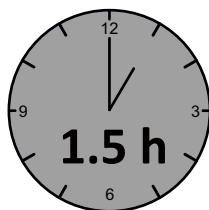

D – bitte lesen sie diese montageanleitung gut durch,
Da wir für fehler, die durch falsche montage entstehen,
Keine haftung übernehmen!

Gb – please read these installation instructions
Through carefully as we cannot accept any liability
For faults occurring as a result of incorrect installation!

Cz – přečtěte si prosím pozorně tento návod k montáži,
Aby jste předešli chybám vzniklých špatnou montáží,
Za které neručíme!

F – veuillez lire attentivement cette notice de montage,
Car nous déclinons toute responsabilité en cas d'erreurs
Découlant d'un montage erroné !

I – prego leggere attentamente le istruzioni per il montaggio,
Poiché decliniamo qualsiasi responsabilità
Per difetti derivanti da montaggio errato.

S - läs monteringsanvisningarna noggrant.
Vi avstår oss allt ansvar för defekter som
Uppstår p.g.a. Felaktig montering.

Hr – pažljivo pročitajte upute za montažu,
Jer otklanjamo svaku odgovornost za pogreške
Nastale uslijed pogrešne montaže.

Slo – prosimo, da pozorno preberete navodila za montažo,
Saj zavračamo vsakršno odgovornost za napake,
Ki bi nastale zaradi napačne montaže.

Nl – leest u alstublieft deze montagehandleiding goed door,
Voor fouten door verkeerde montage zijn wij niet verantwoordelijk.

Pl – prosze uwaznie zapoznac sie z instrukcja montazu,
Poniewaz nie ponosimy odpowiedzialnosc za niewlasciwy montaz.

Hu – Kérjük, olvassa el figyelmesen
ezt az összeszerelési útmutatót,
mert a helytelen összeszerelésből
a dódó hibákért nem vállalunk felelősséget!

SK – Prosíme, dobre prečítajte si tento návod na montáž,
pretože nepreberáme žiadne ručenie za chyby,
ktoré vzniknú na základe chybnej montáže!

RO – Vă rugăm să cititi cu atenție aceste instrucțiuni
de montaj deoarece nu preluăm garanția pentru defecte
ce apar datorită unui montaj incorect!

RUS – Пожалуйста, внимательно ознакомьтесь ù
с данной инструкцией по монтажу, поскольку мы не
несем ответственности за ошибки, причиной которых
является неправильный монтаж.

TU – Ilkonce kullanma klavuzunu iyi okuyun,
yalnis montaj yapasaniz bunun sorumlusu biz degiliz.

ES – Se ruega leer con atención las instrucciones
de montaje debido a que declinamos cualquier
responsabilidad
por defectos derivados de un montaje erróneo.

01PETI x 4

07SCS

07SCI

07SCH

07SCS

07SCI

01TO

07TR x 2

07RI

07FI

07RI

01FO

07FI

SERVICEKARTE

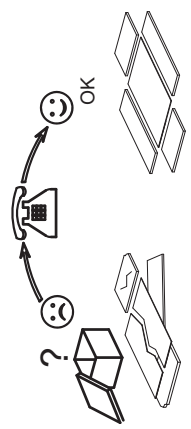
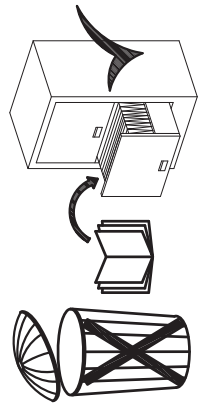

07FI

07FI

07RI

05FA

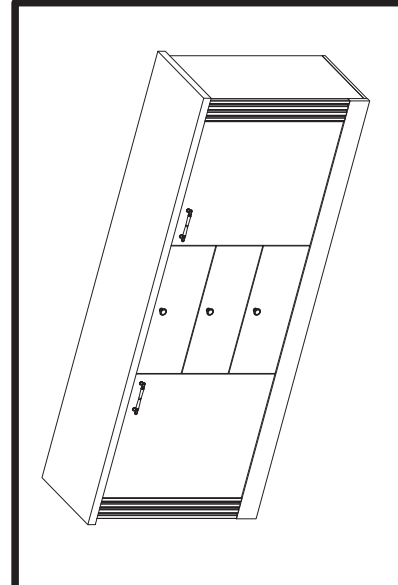

07SPO

07FC

01CA

X3

05FA

05FA

07SP

07SP

01FAF

SERVICEKARTE

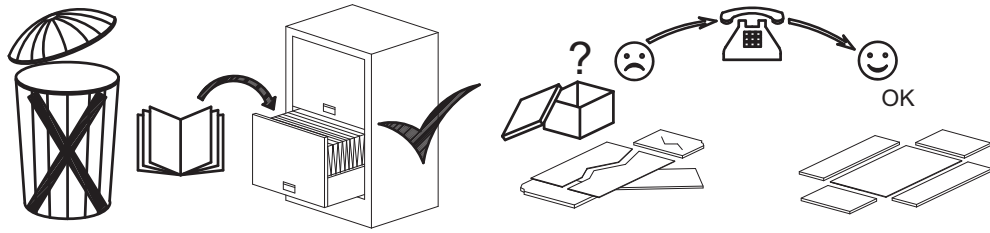

H2E

x4

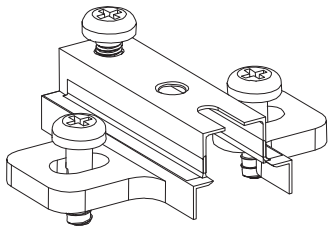

POM

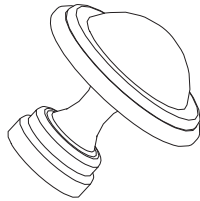

x3

CL

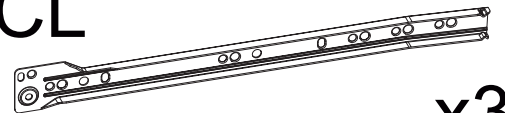

x3

C90

x4

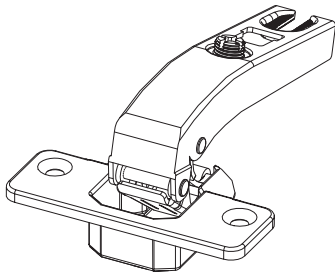

CR

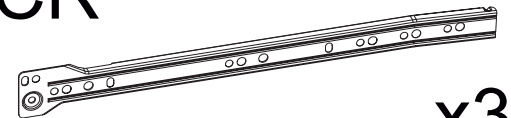

x3

V415

ø4x15 mm x8

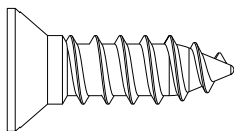

T420 x3

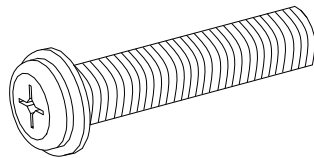

ø4x20 mm

CL

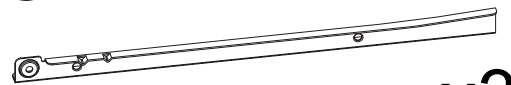

x3

CR

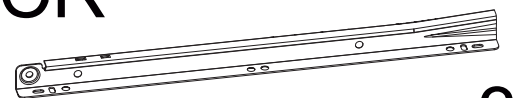

x3

P

ø60

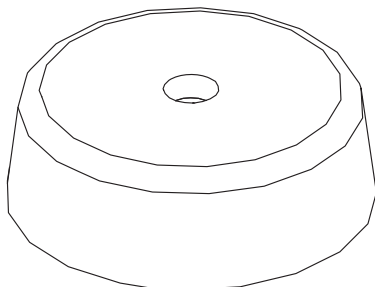

x6

MAN

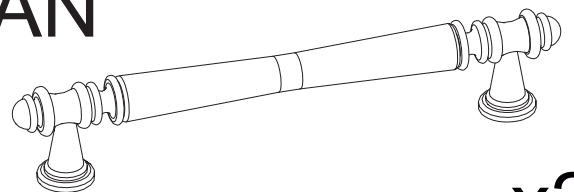

x2

V4530

x6

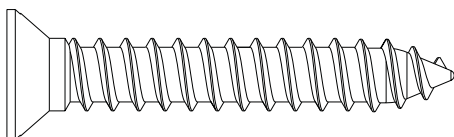

ø4.5x30 mm

T420 x4

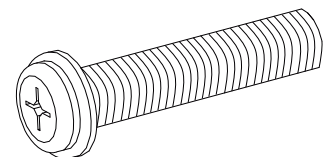

ø4x20 mm

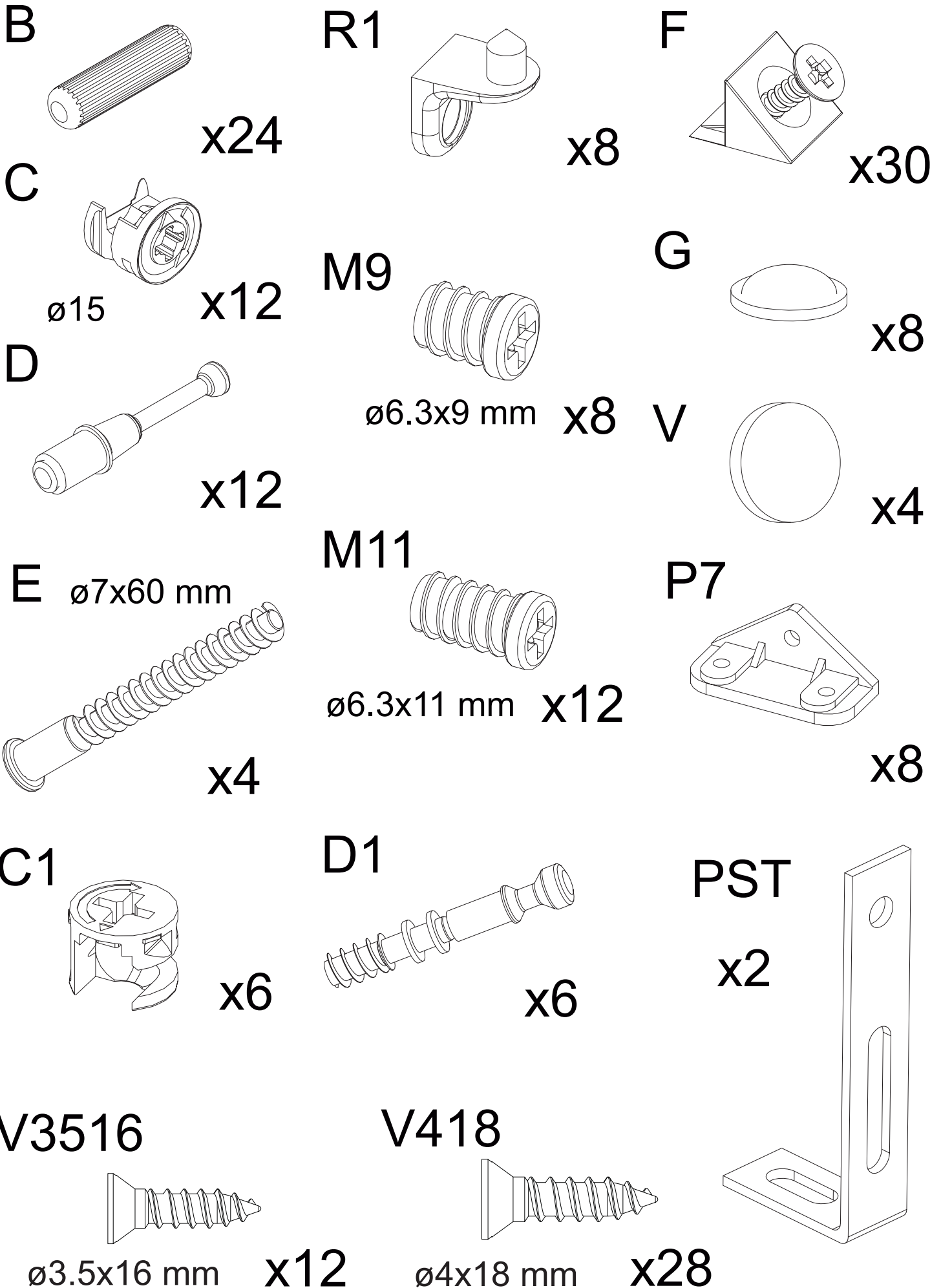

1

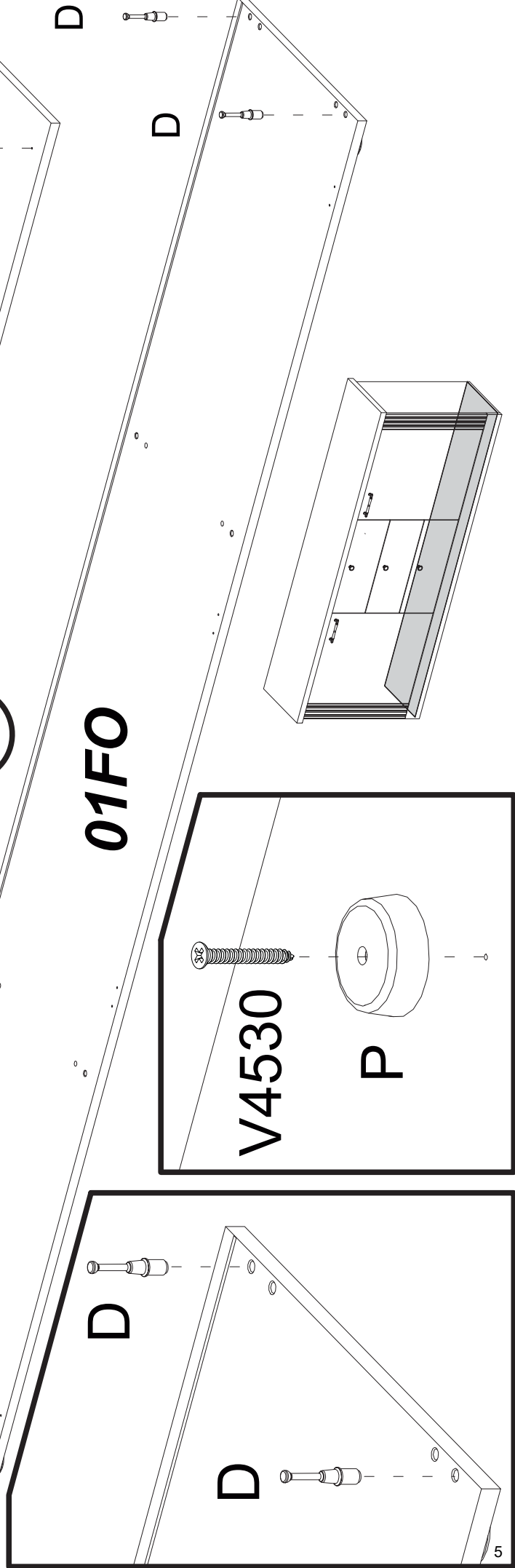
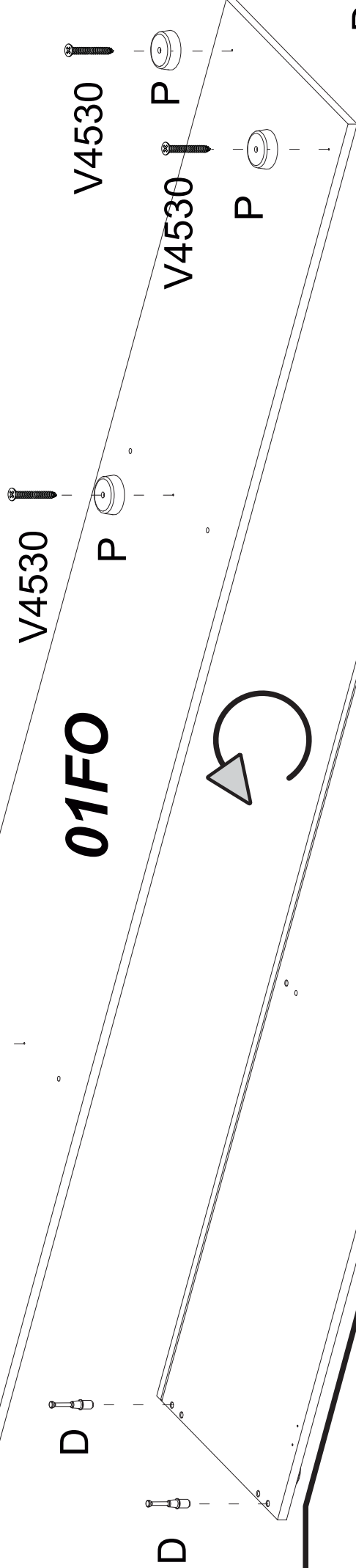
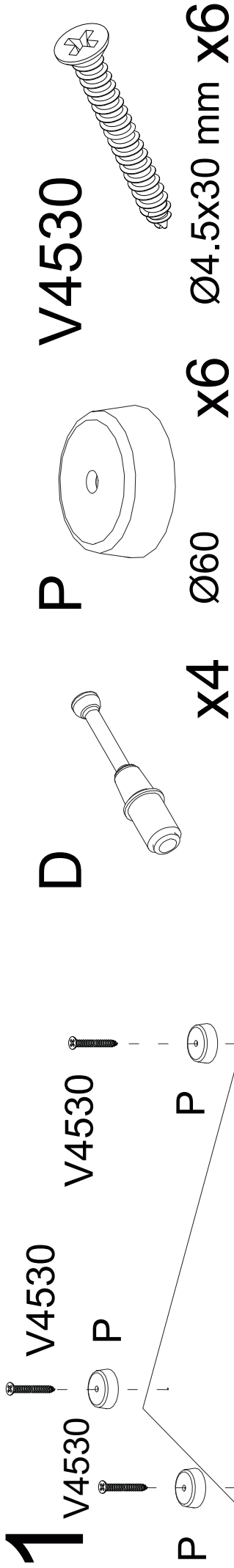

2a

CL

CR

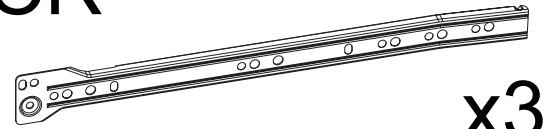
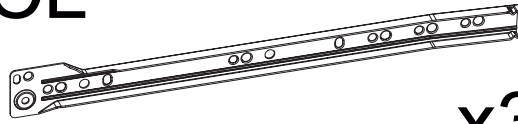

x3

x3

M11

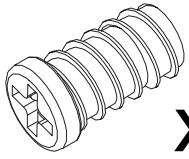

x12

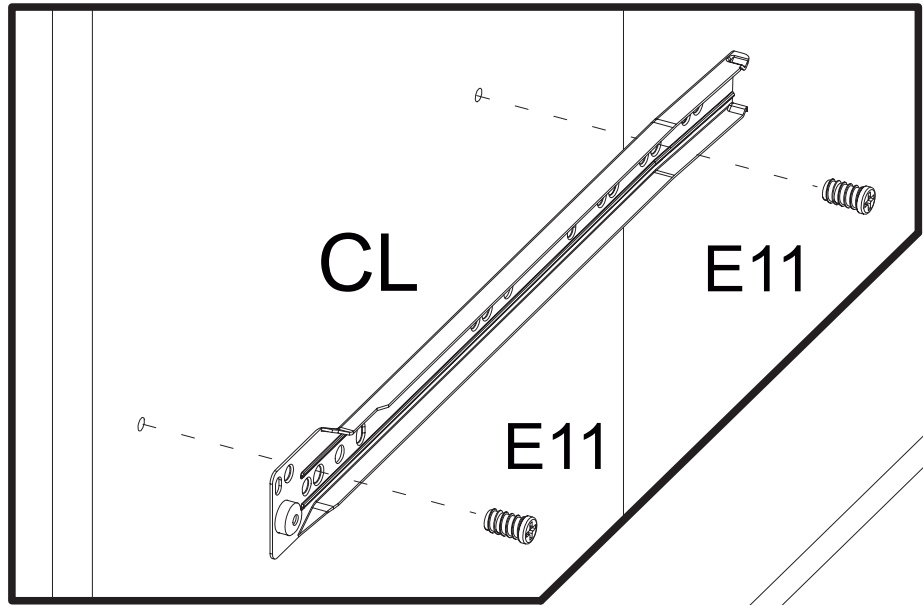

CL

E11

E11

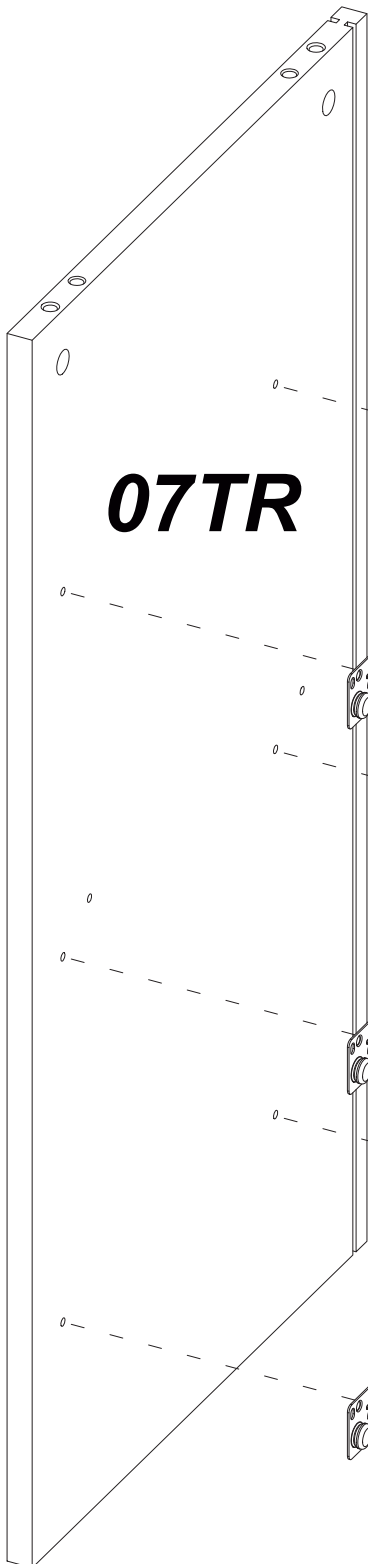

07TR

CL

CL

CL

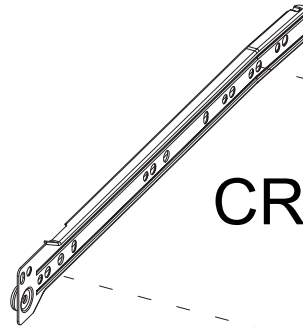

CR

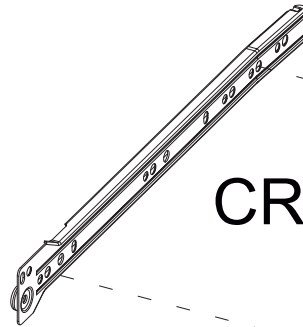

CR

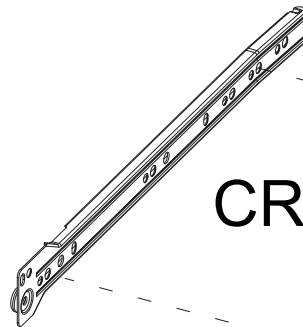

CR

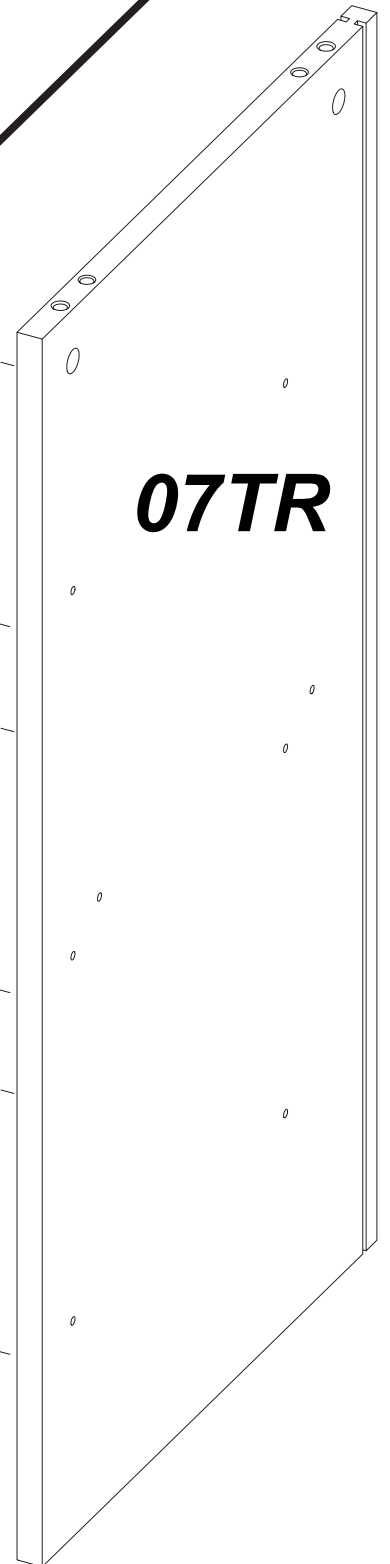

07TR

2b

R1

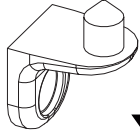

x4

M9

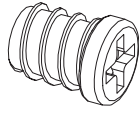

x4

B

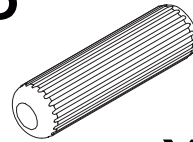

x8

D

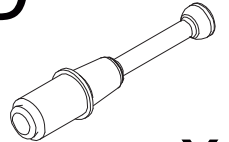

x4

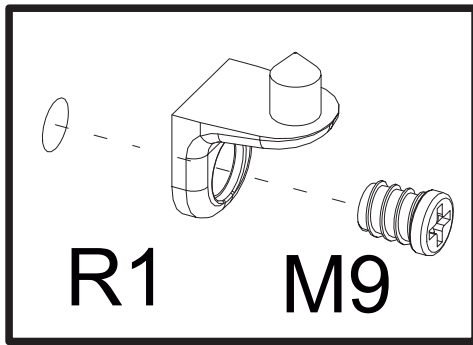

R1

M9

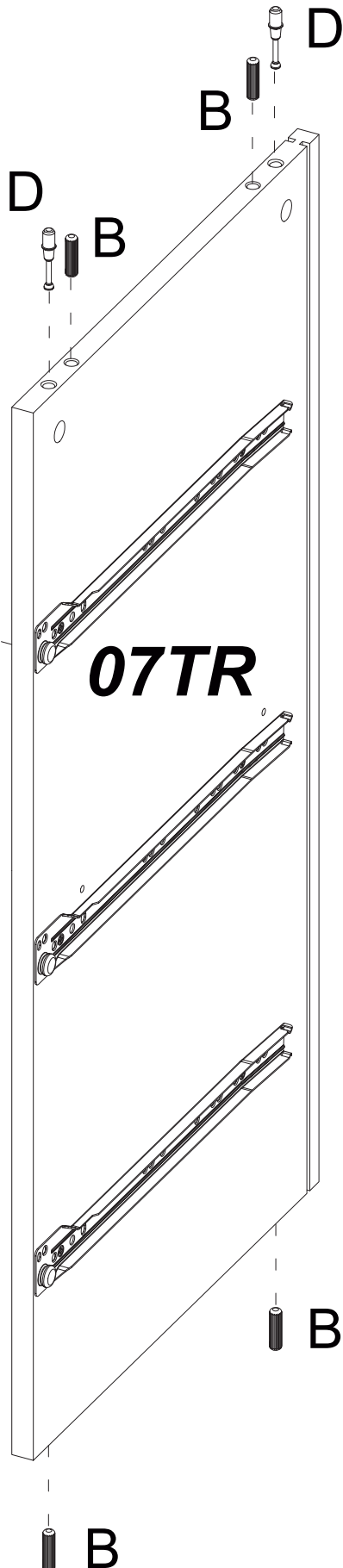

R1+M9



07TR

R1+M9

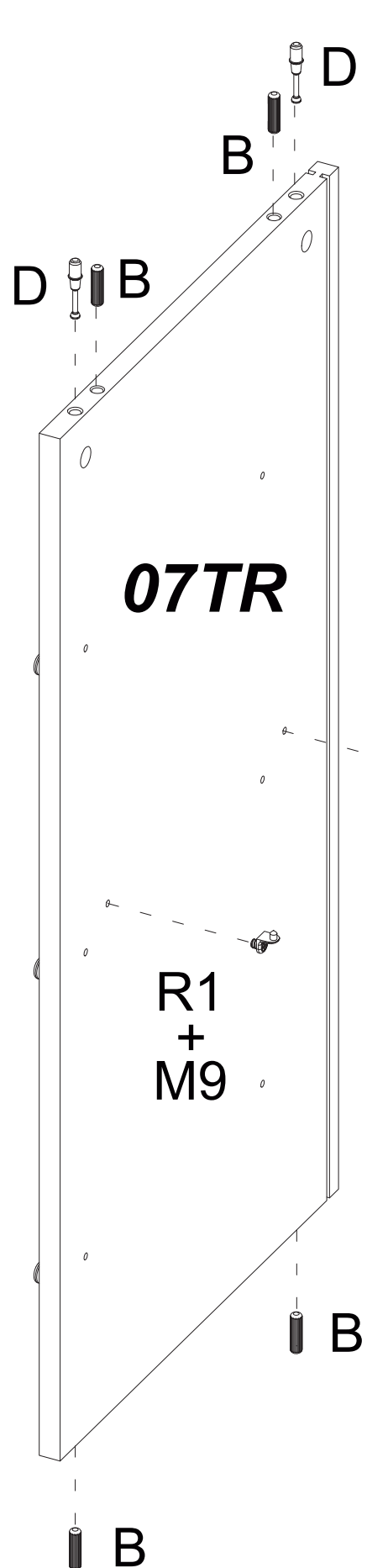

07TR

R1 + M9

R1 + M9

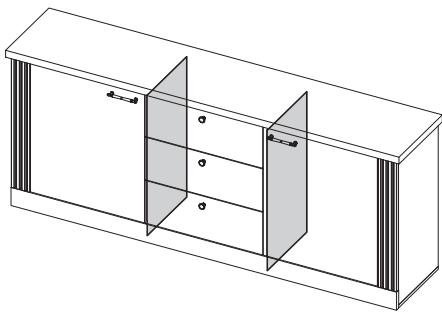

3

R1

M9

B

D

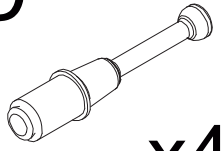
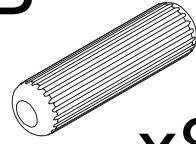
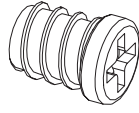
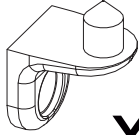

x4

x4

x8

x4

D

B

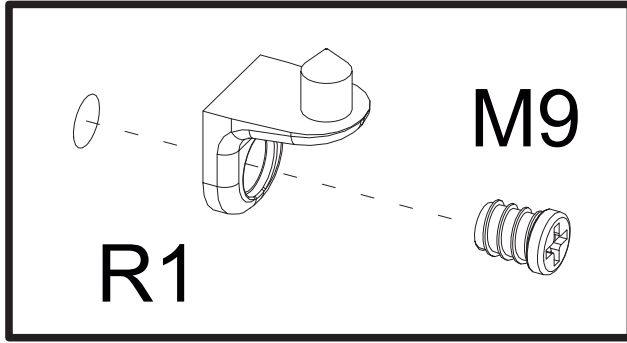

M9

R1

D



B

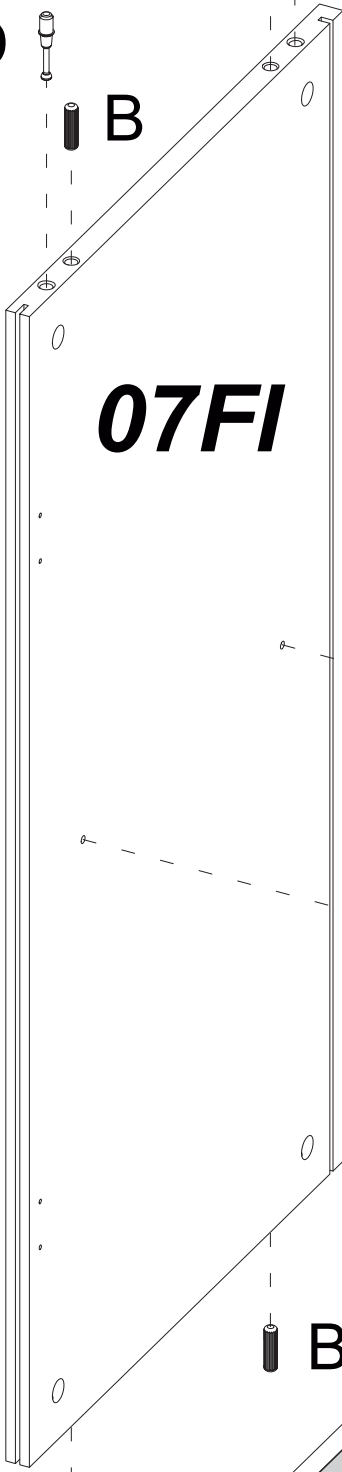

07FI

R1+M9



R1+M9



R1+M9



R1+M9



B



B

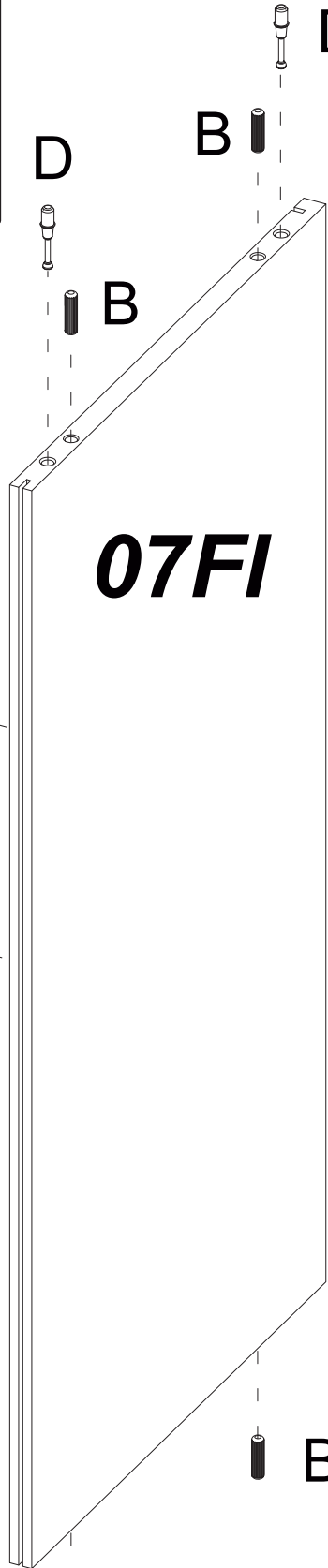
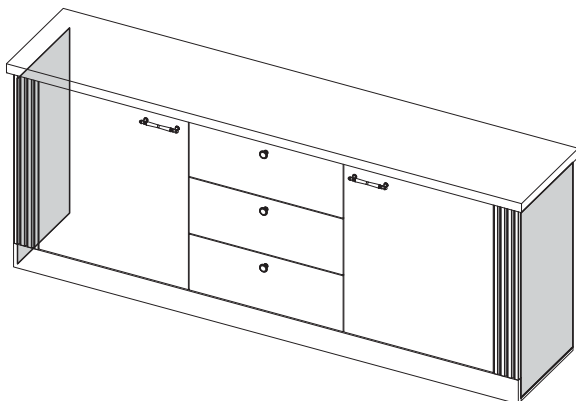

07FI

D



B



B



D



B



B



4

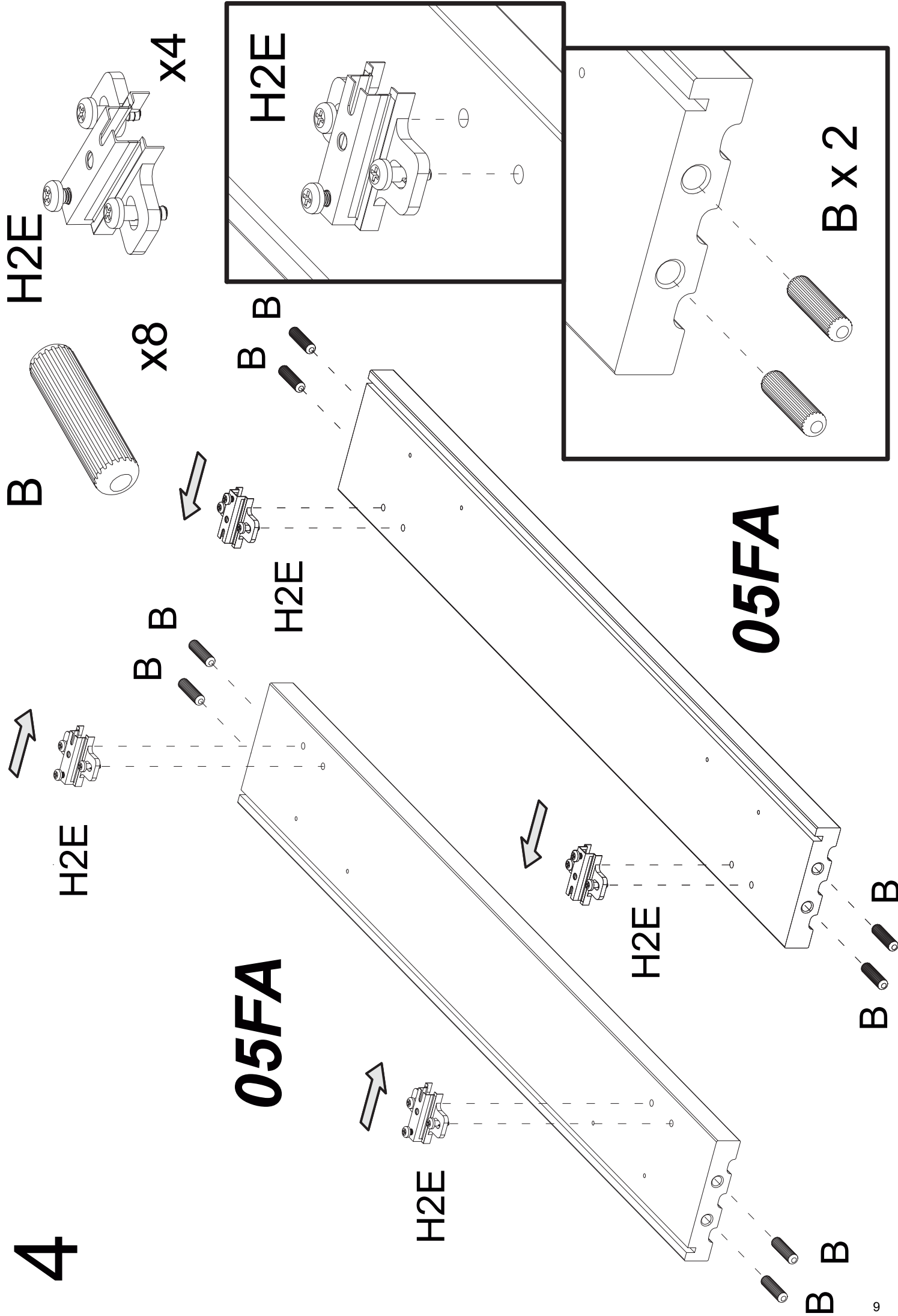

5

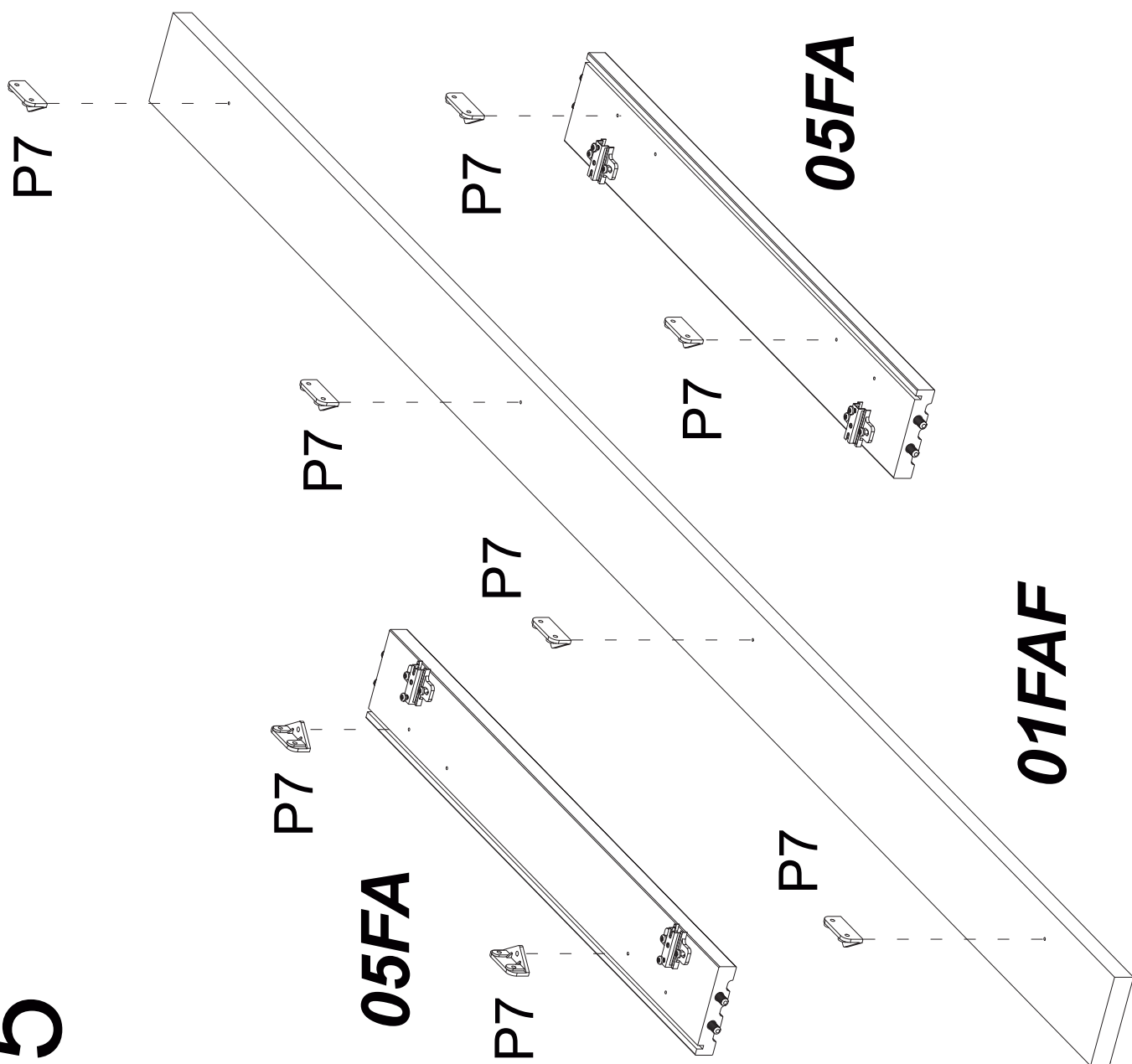

P7

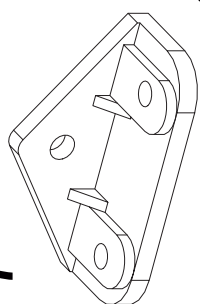

x8

V418

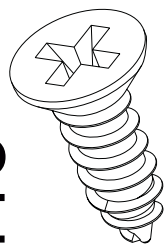

x8

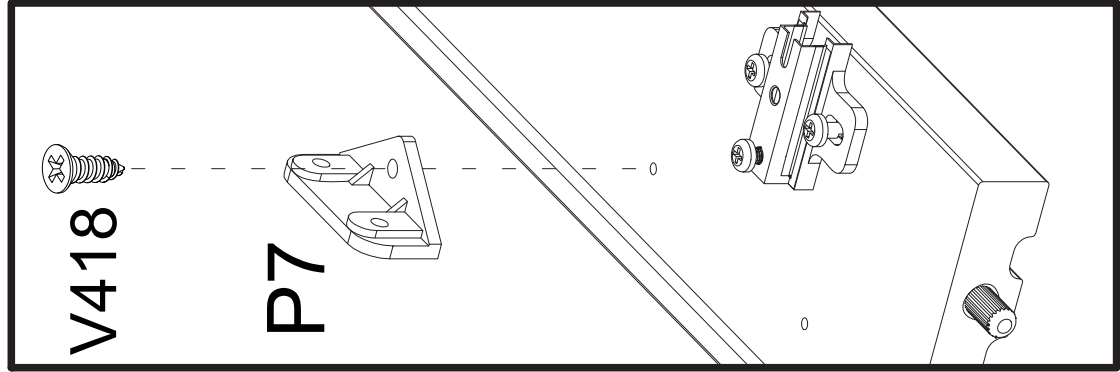

V418

P7

V418

P7

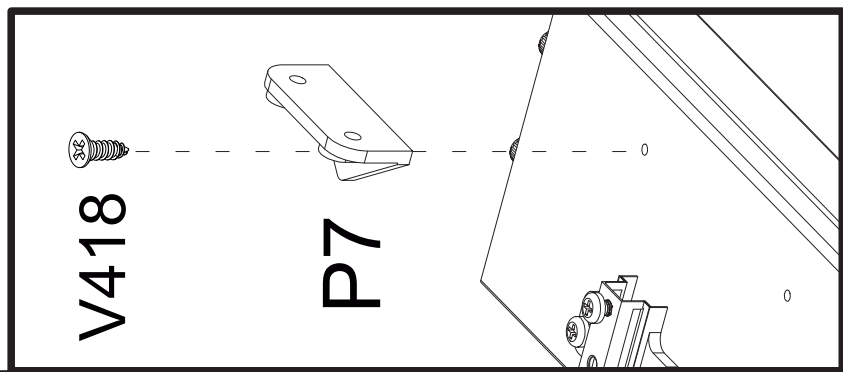

V418

P7

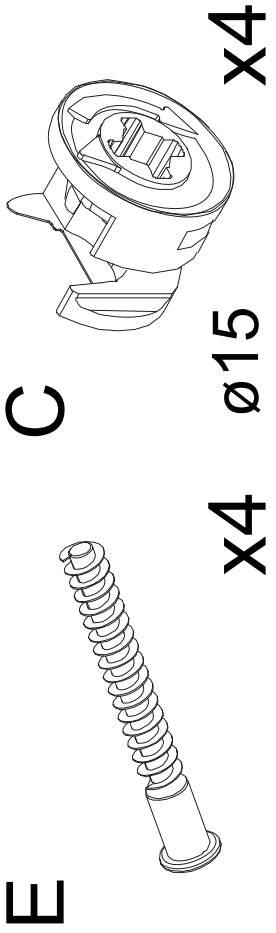

6
07FI

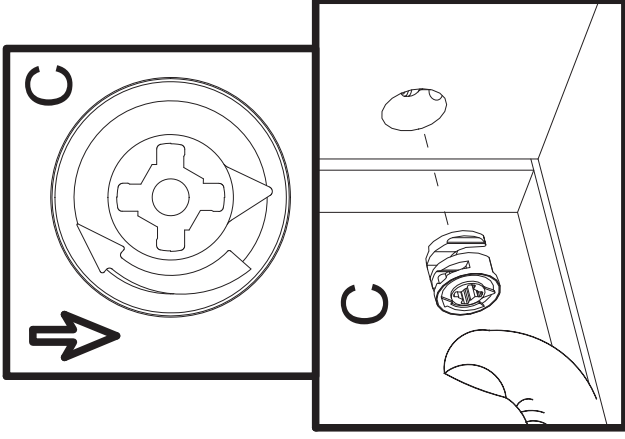

x4

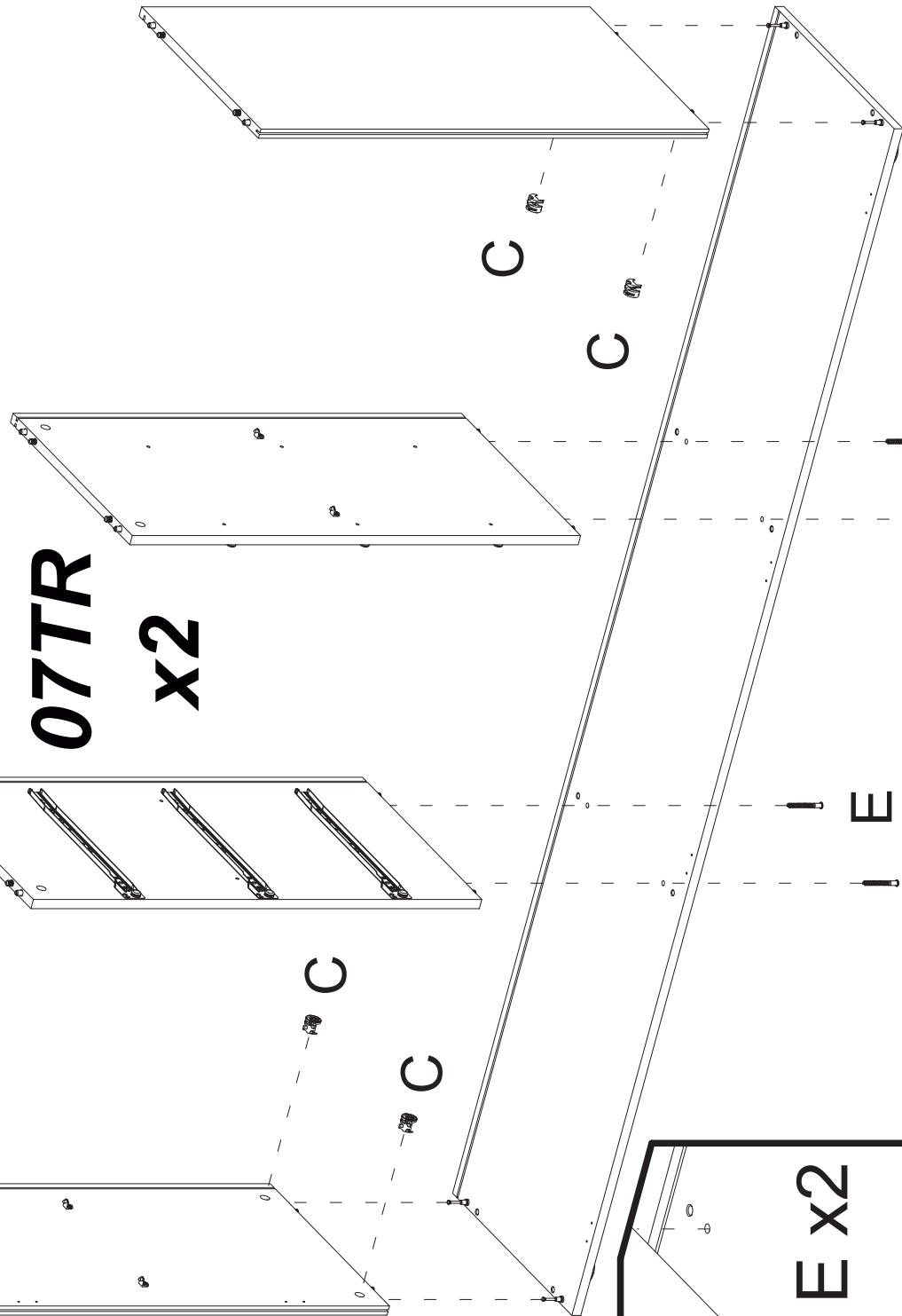

07FI

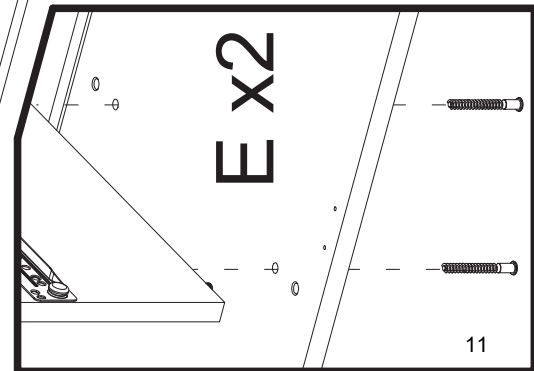
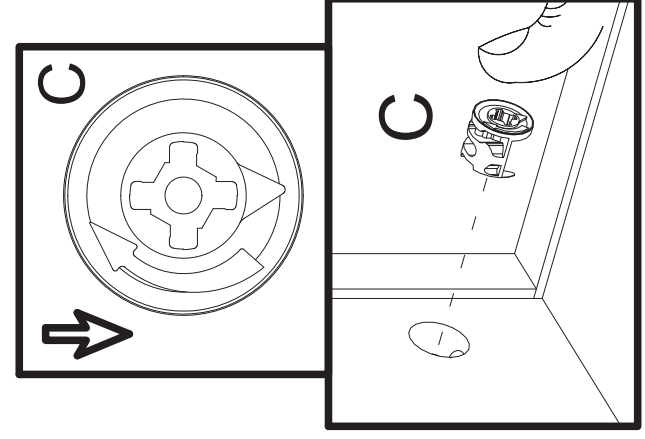

7

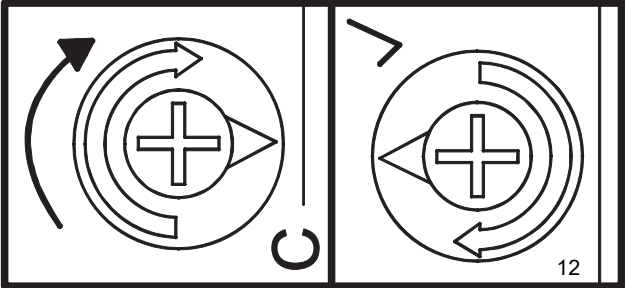
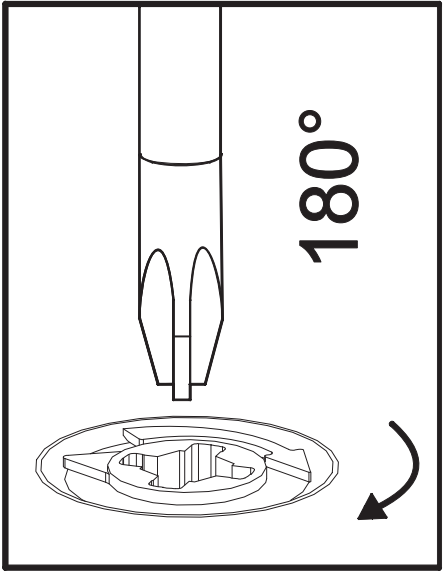
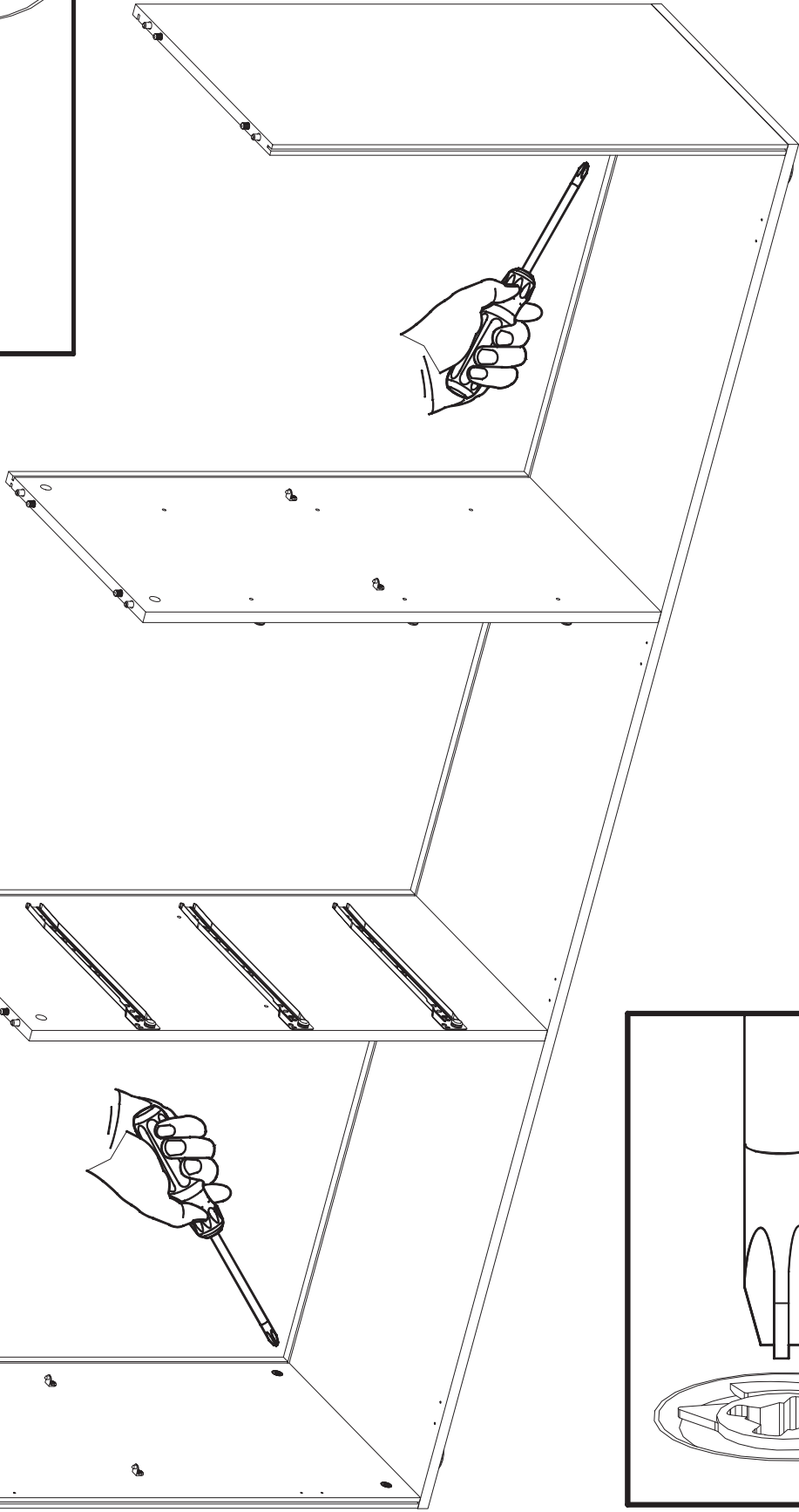
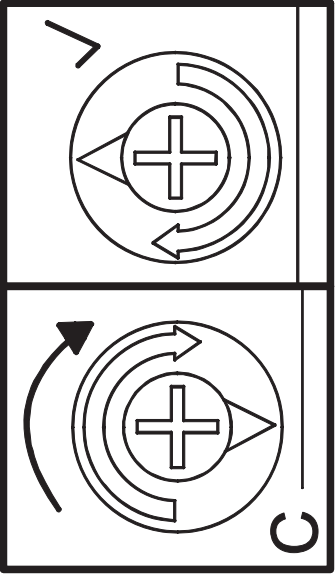
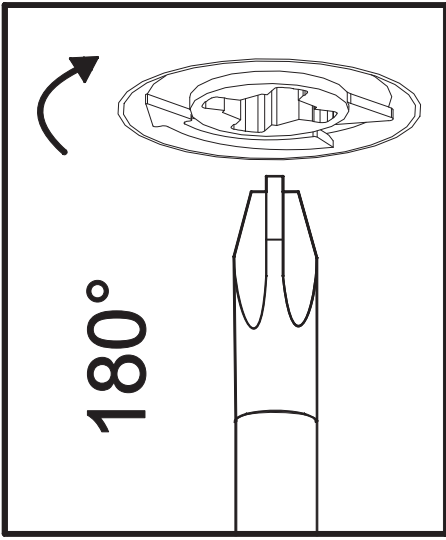

8

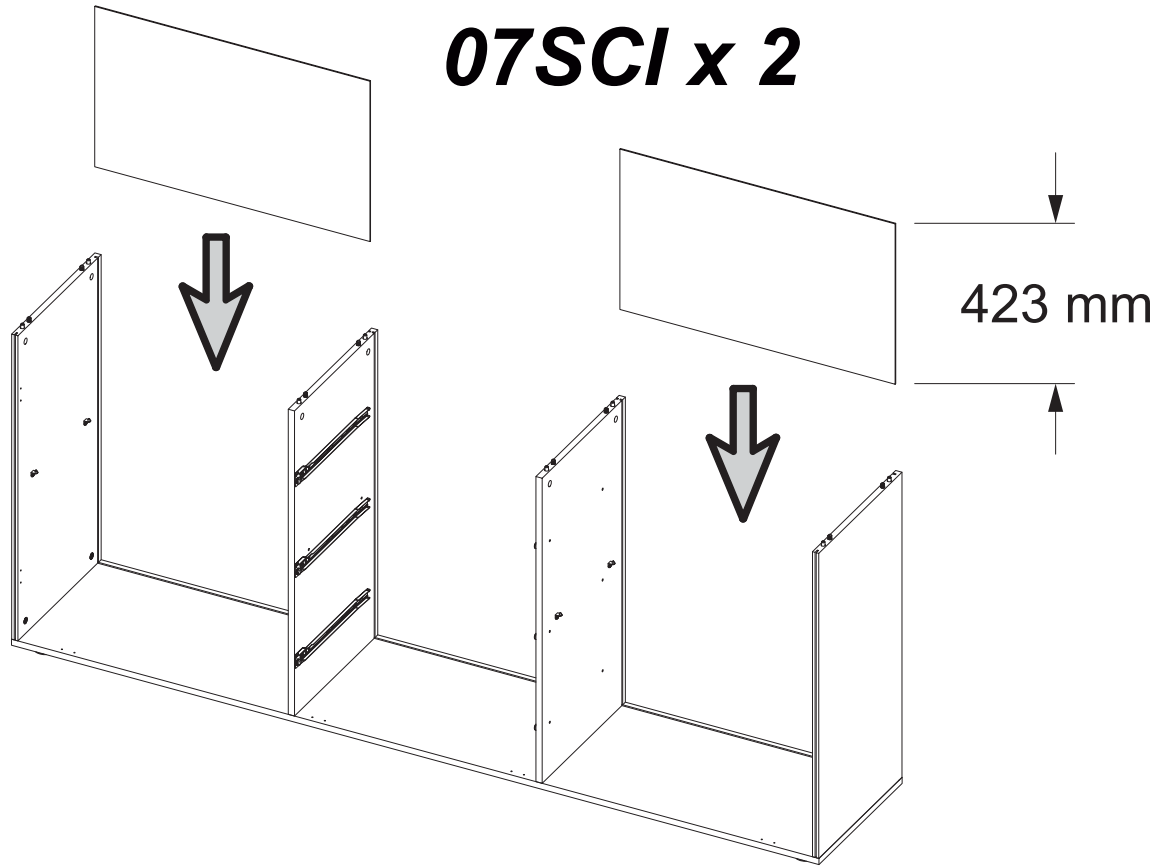

9

07RI

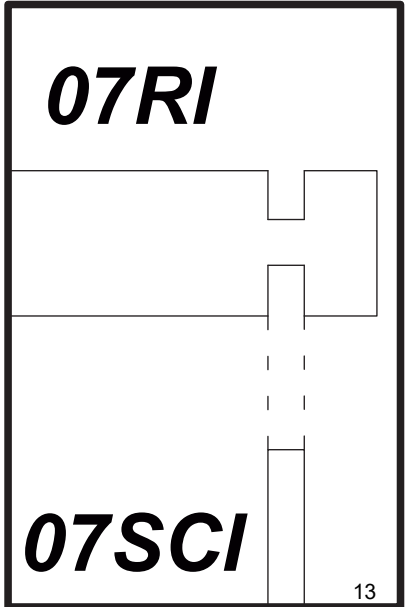
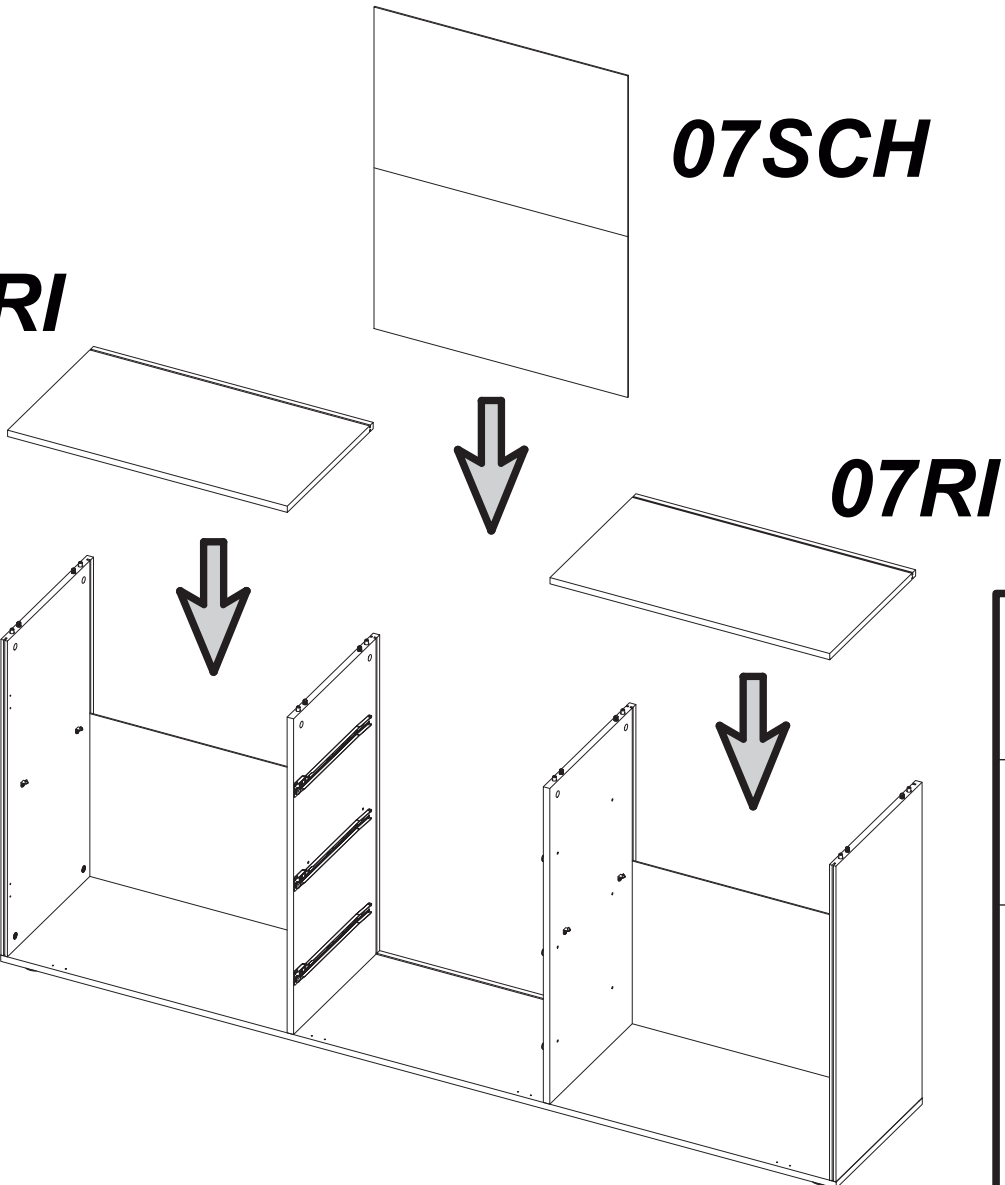

10

07SCS x 2

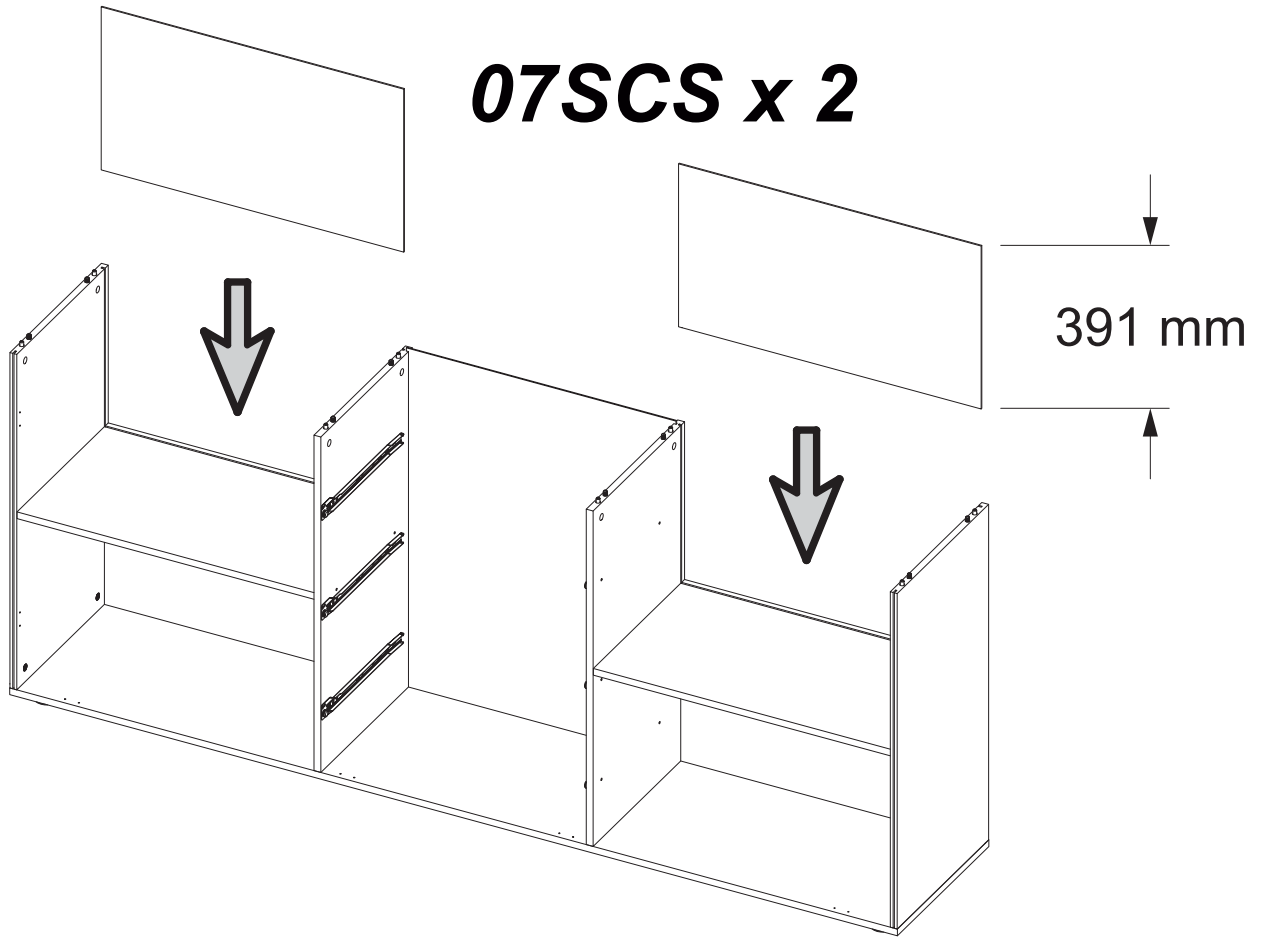

11

V418

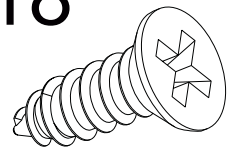

x8

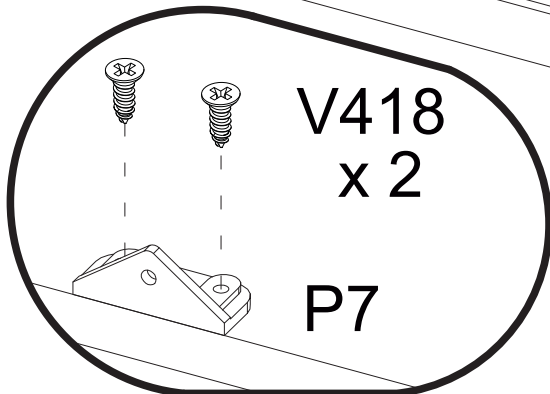
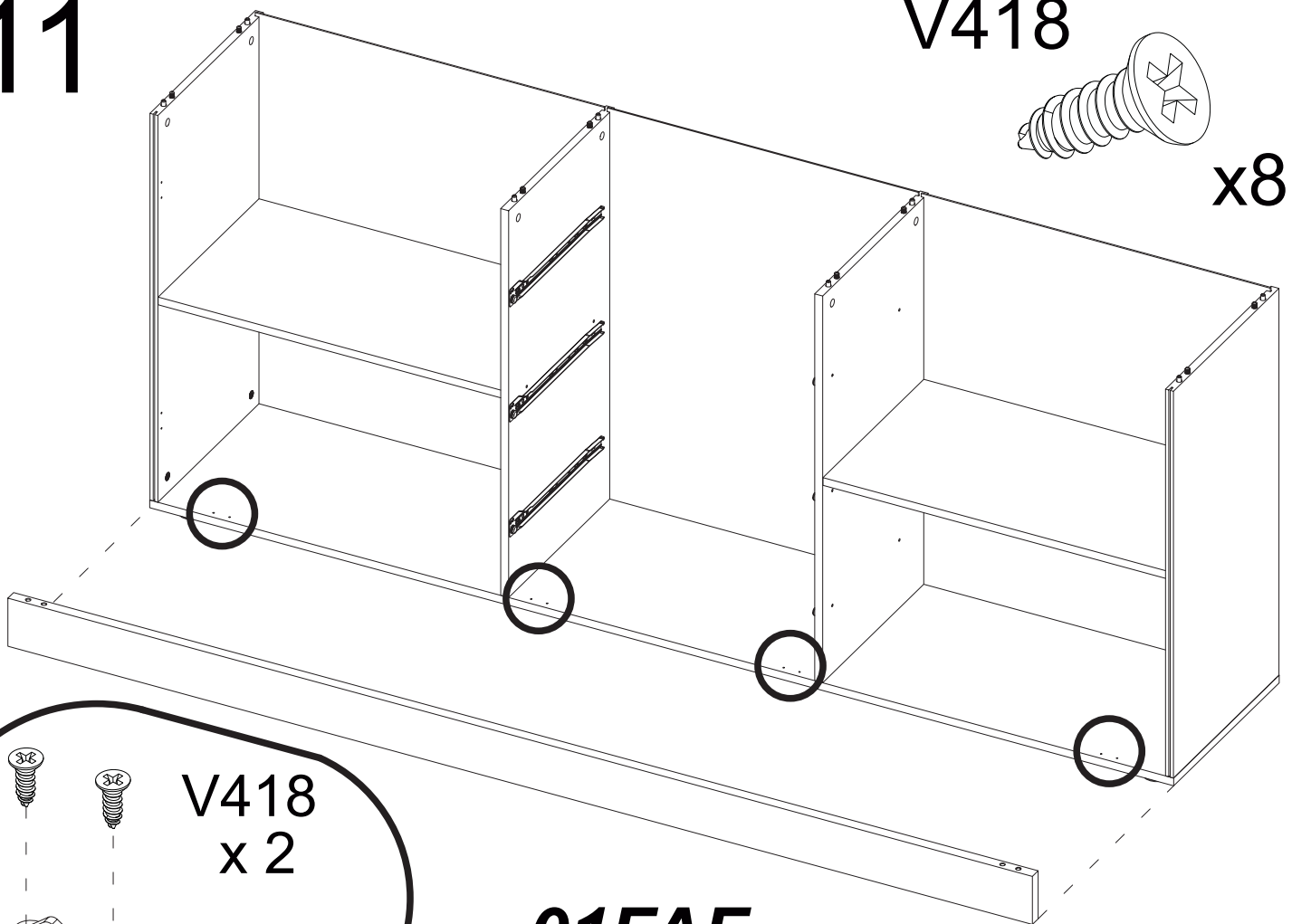

01FAF



12

01PETI x 2

+
05FA

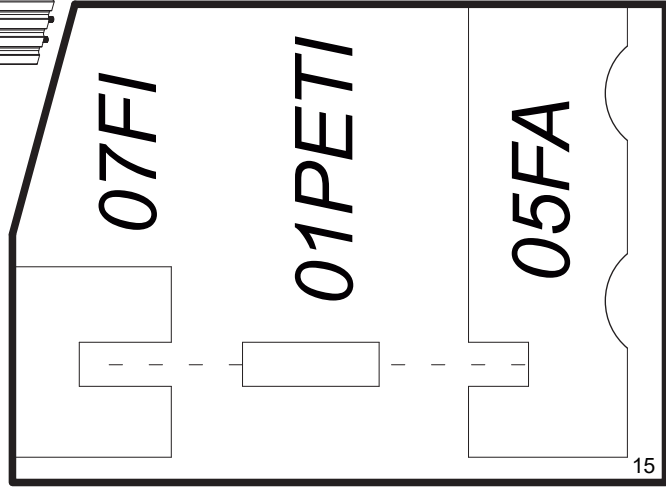
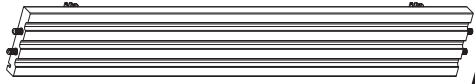
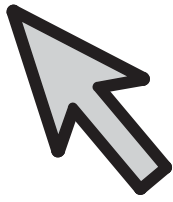

V418

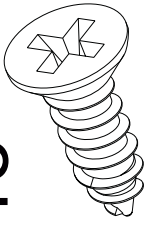

x8

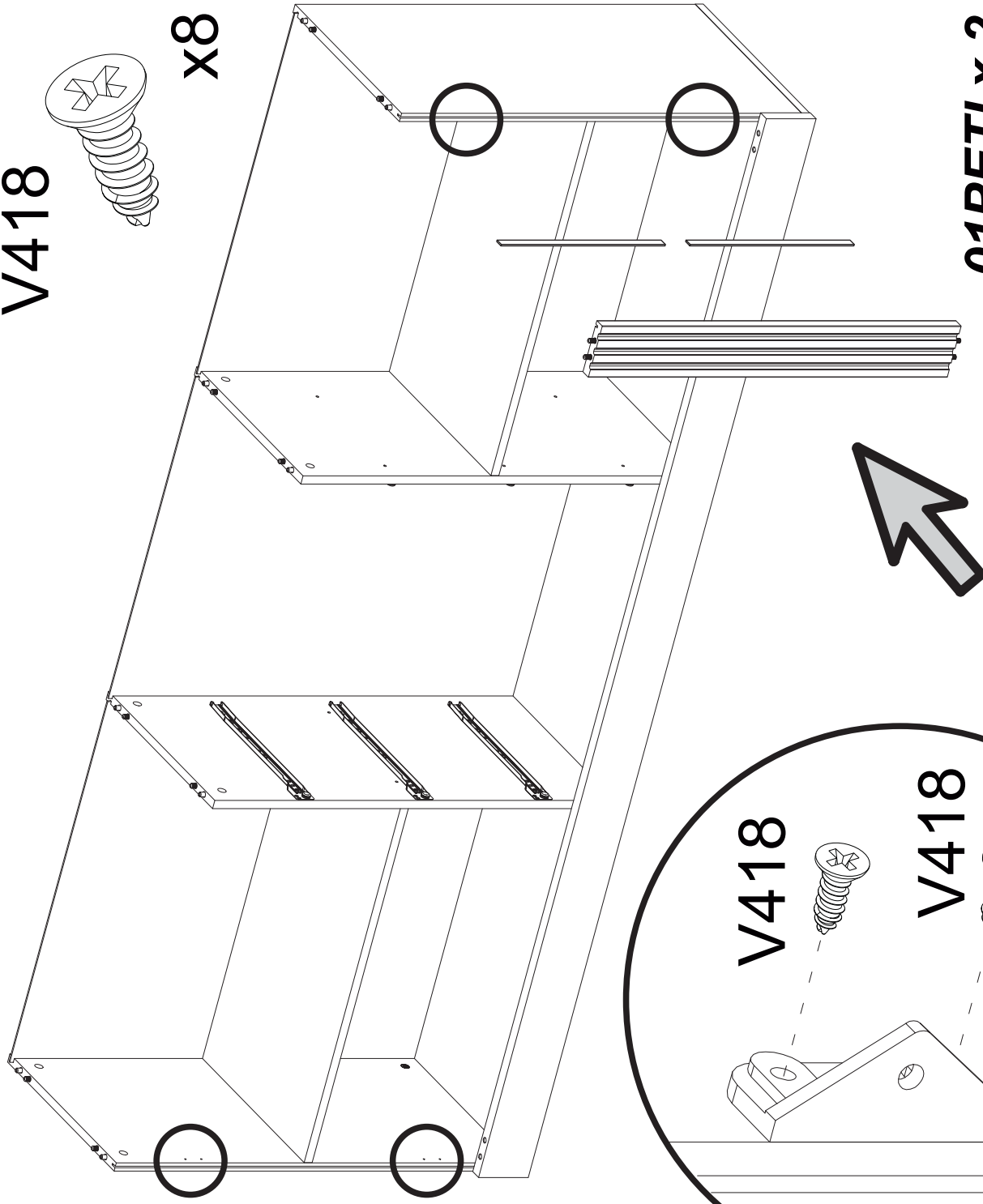

01PETI x 2

+
05FA

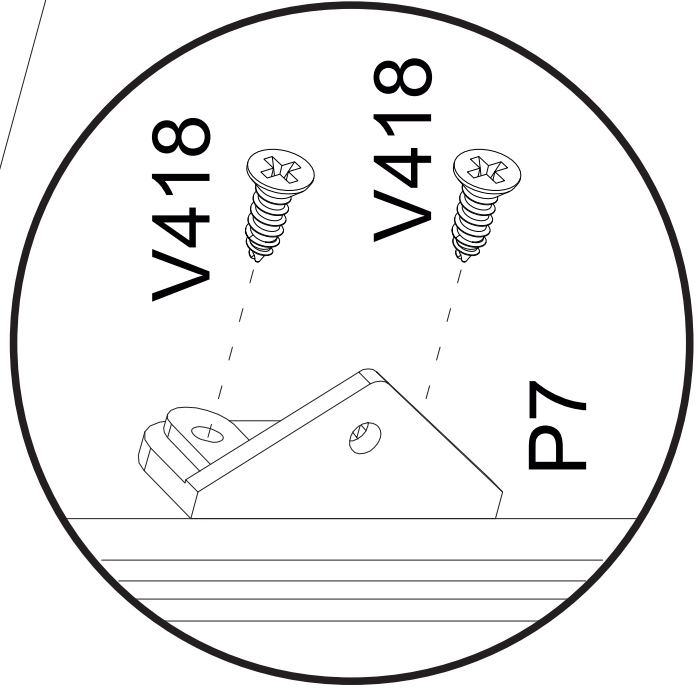

13

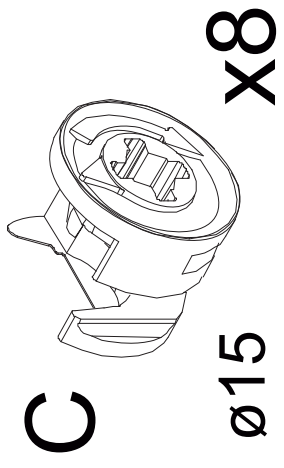
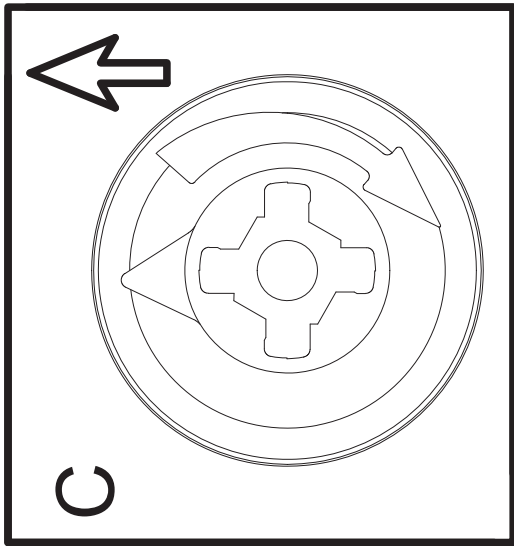

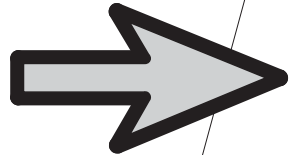
0770 

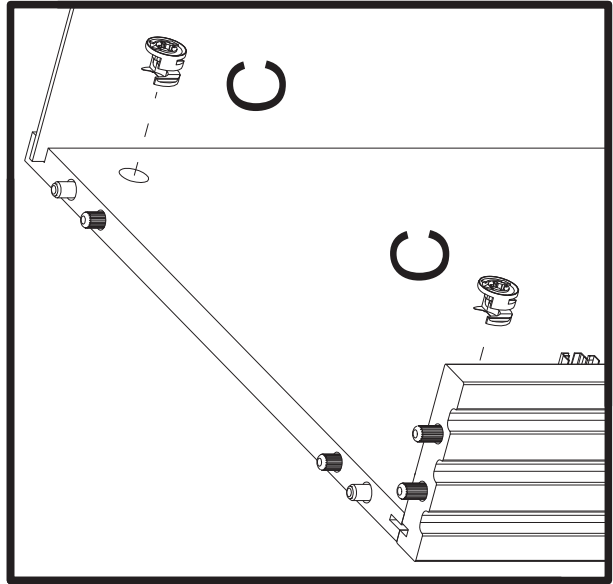
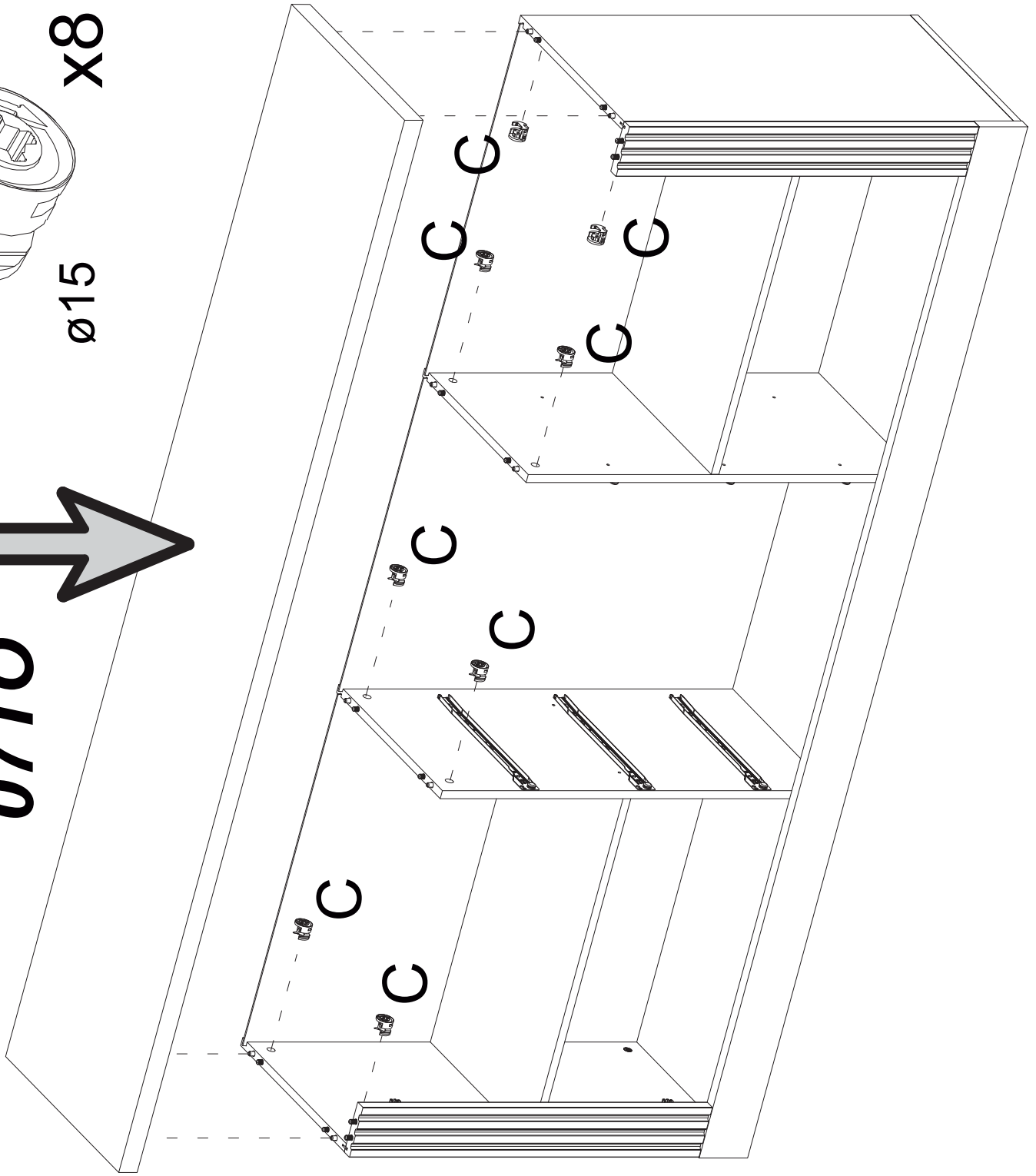

14

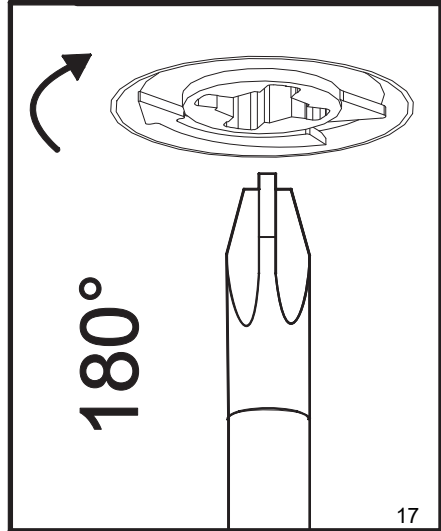
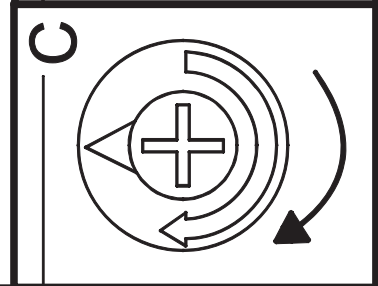
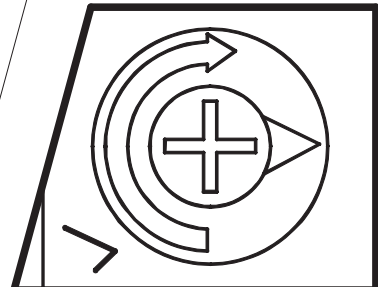
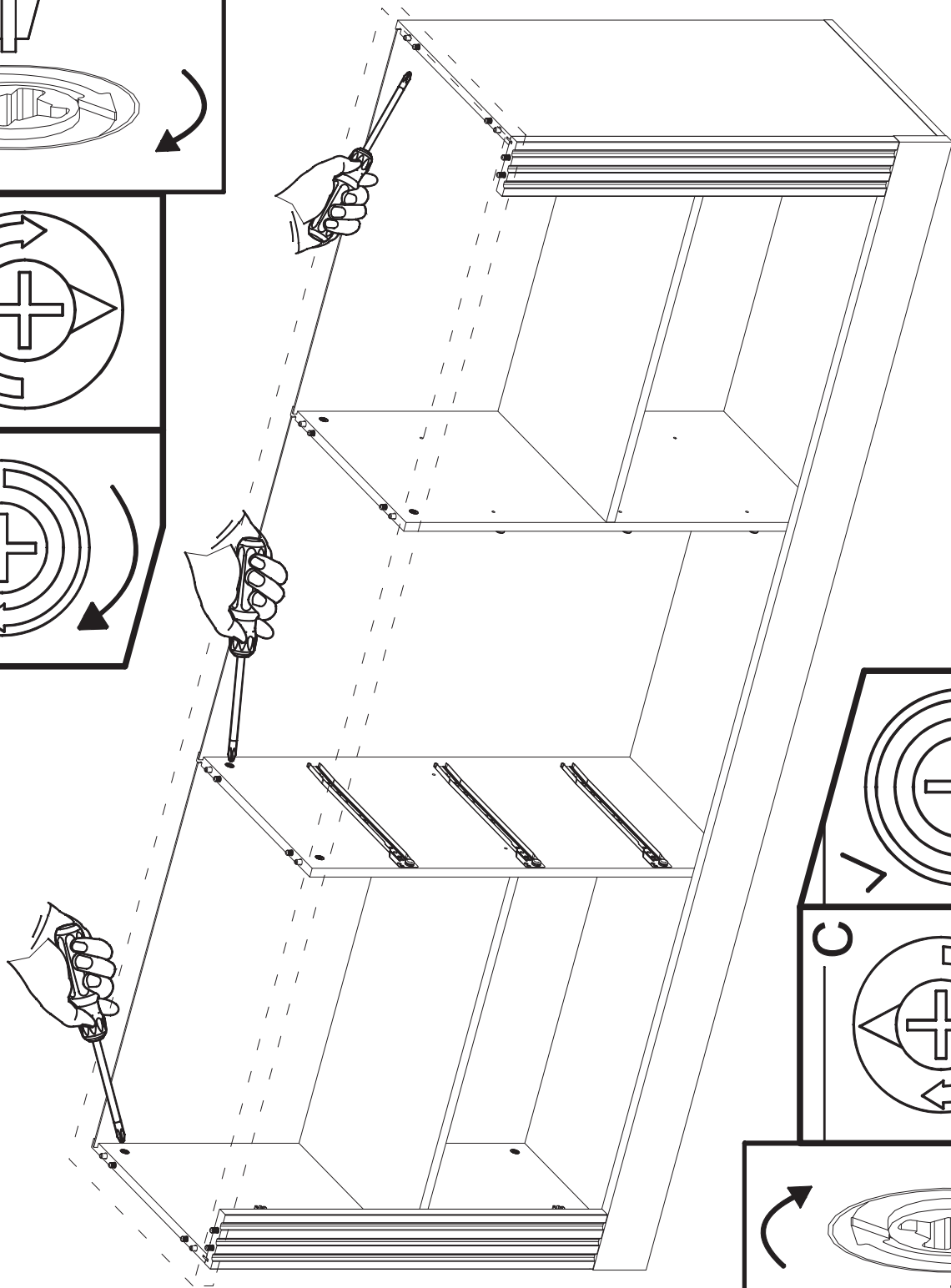
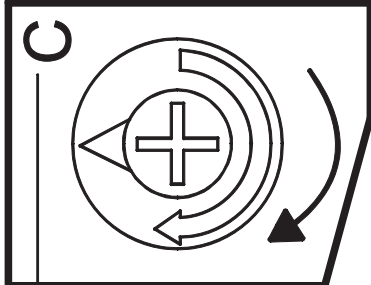
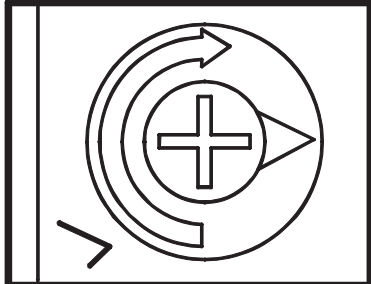
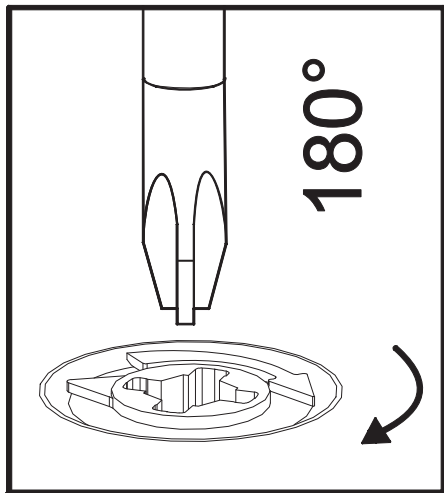

15

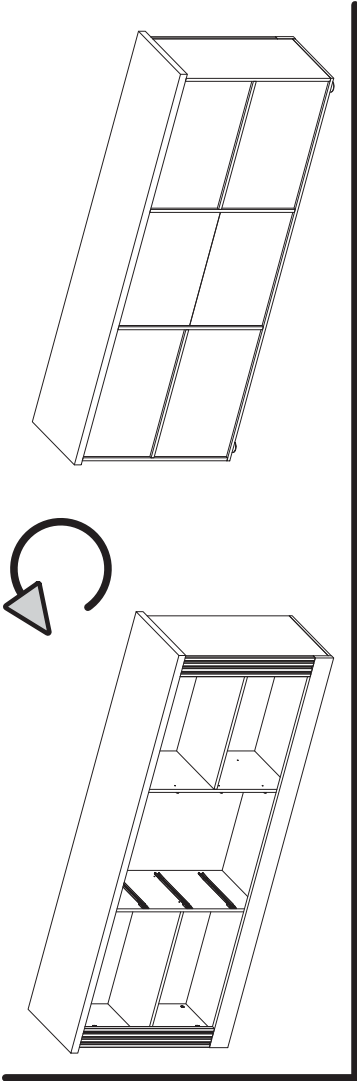
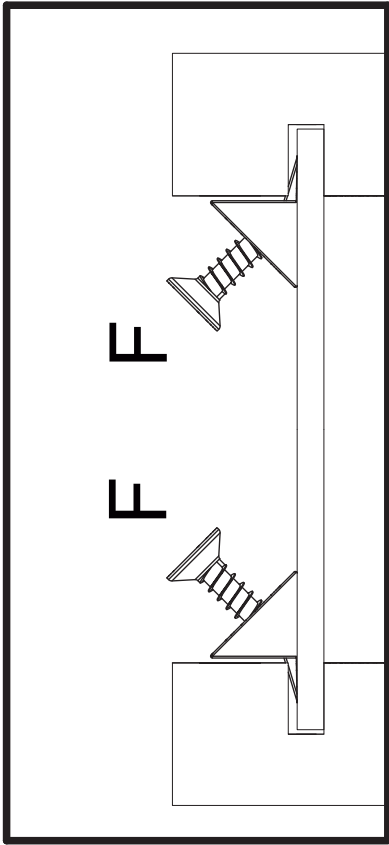

F

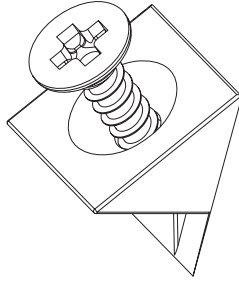

x24

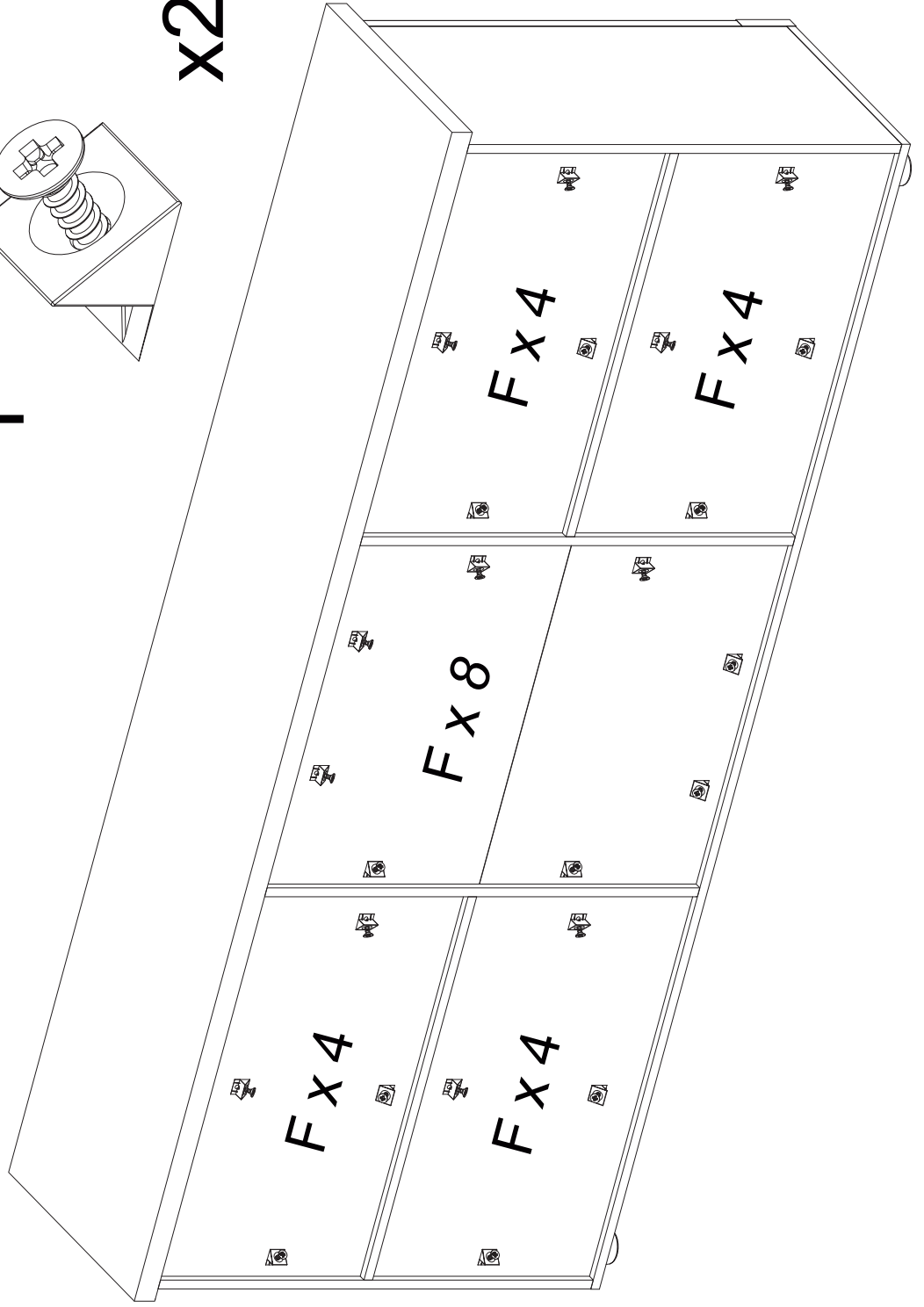
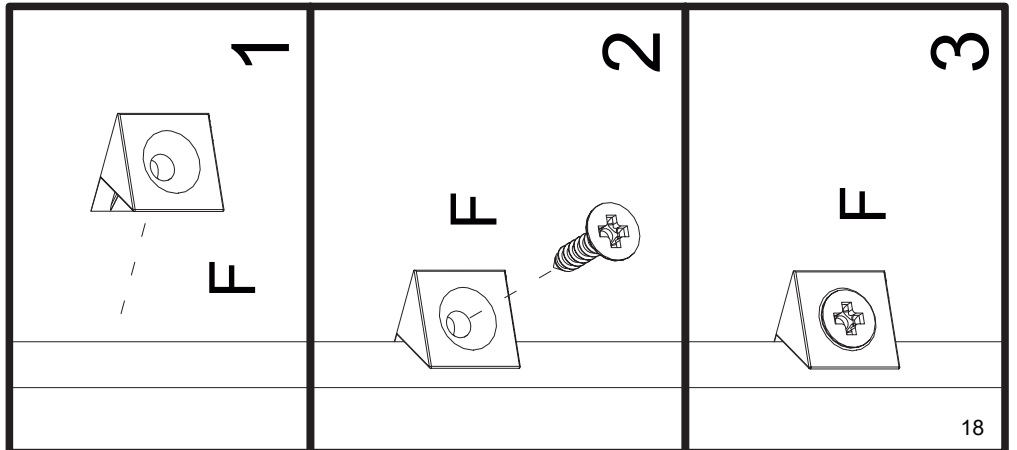

- POM x3
- V3516 x6
- DR x3
- F x6
- V3516 x12
- D1 x6
- DL x3
- T420 x3
- C1 x6
- D1 x3
- DL x3

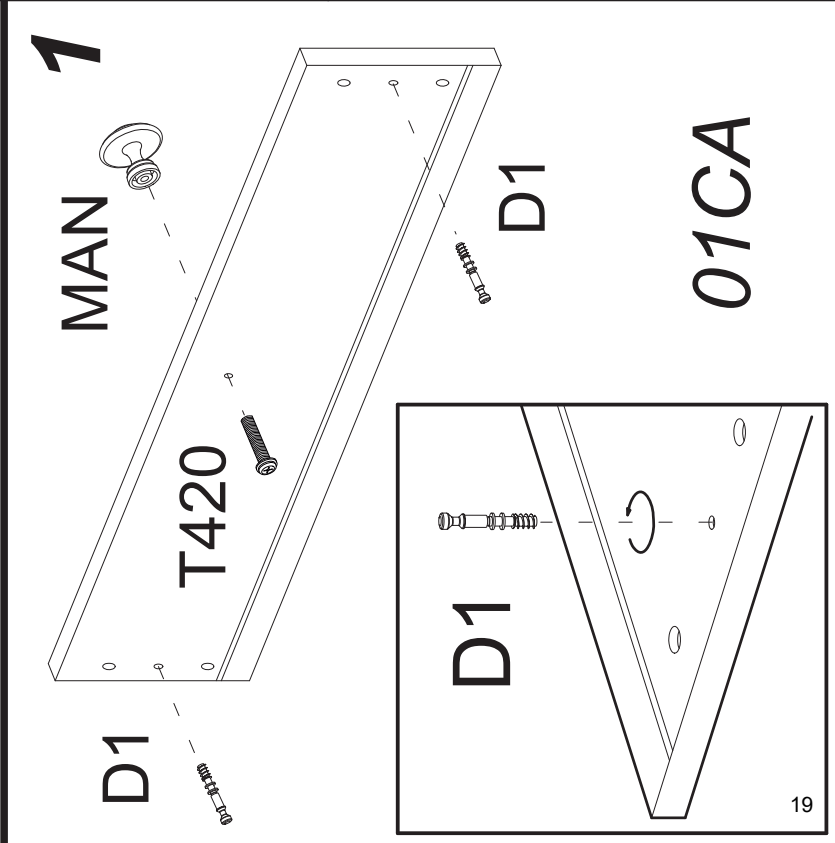
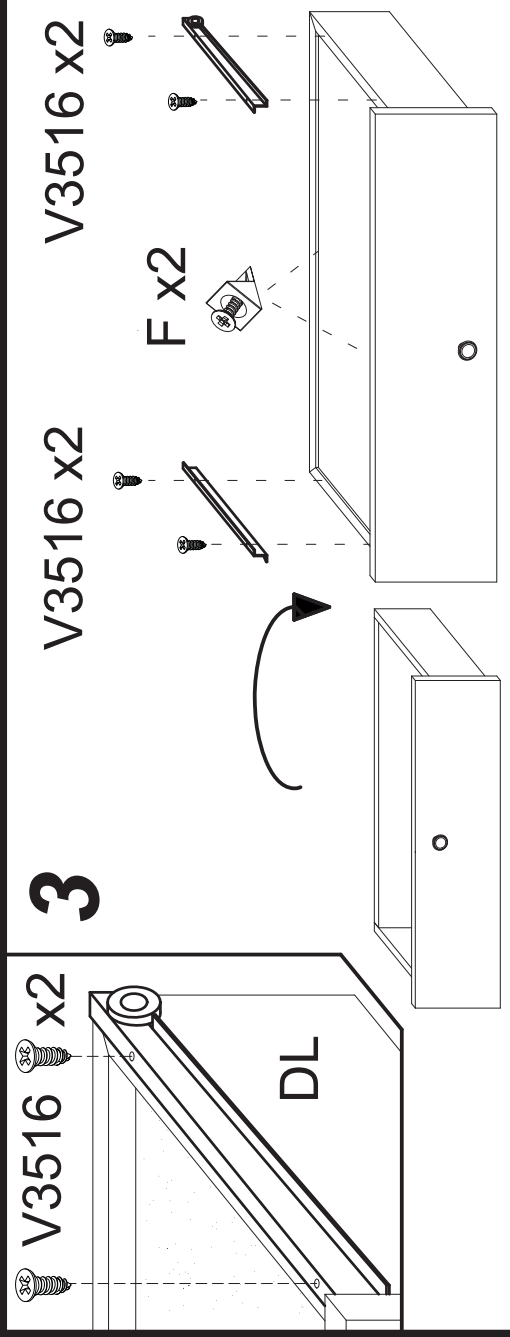
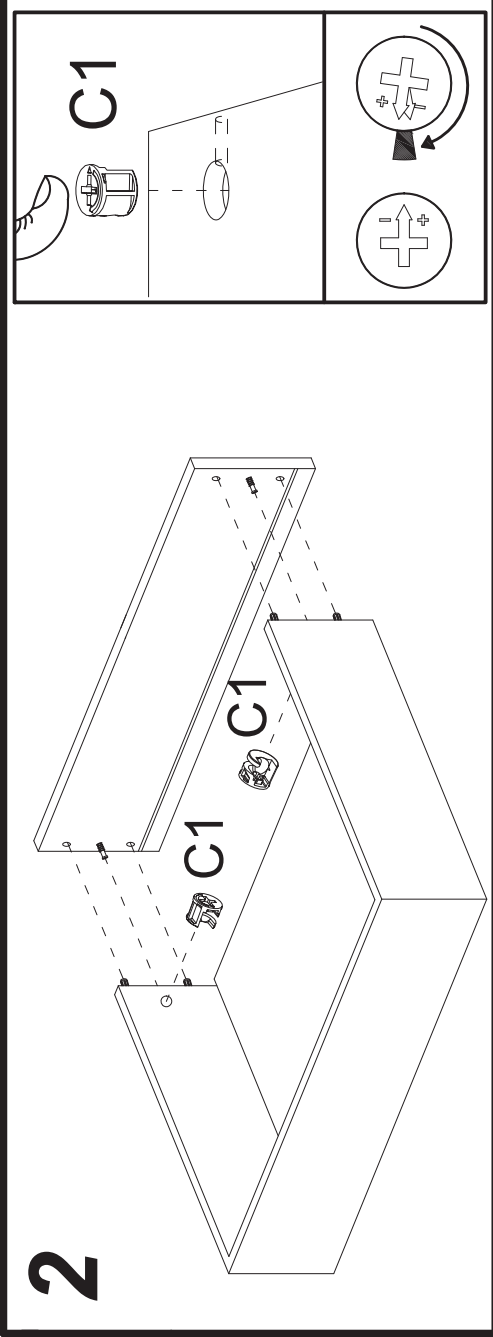
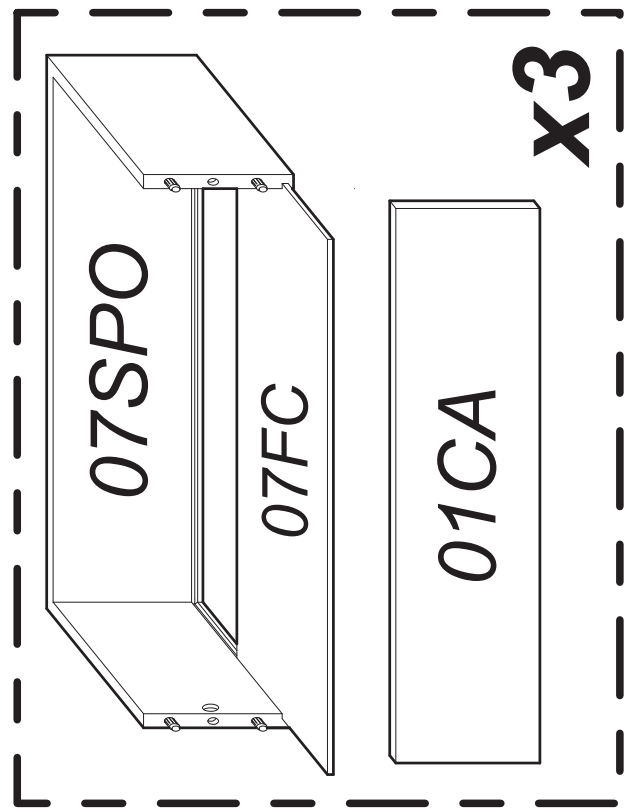



Attenzione!!! Aprire le cerniere prima del montaggio
Attention!!! Open hinges before assembly
Achtung!!! Scharniere vor der Montage öffnen
Attention!!! Ouvrir les charnières avant l'assemblage
Atención!!! Abrir las bisagras antes del montaje



1



2



3



17

T420

MAN

V415

C90

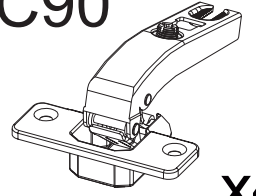
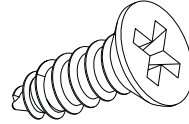
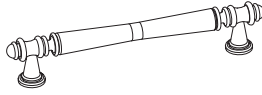
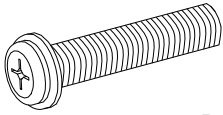

x4

x2

x8

x4

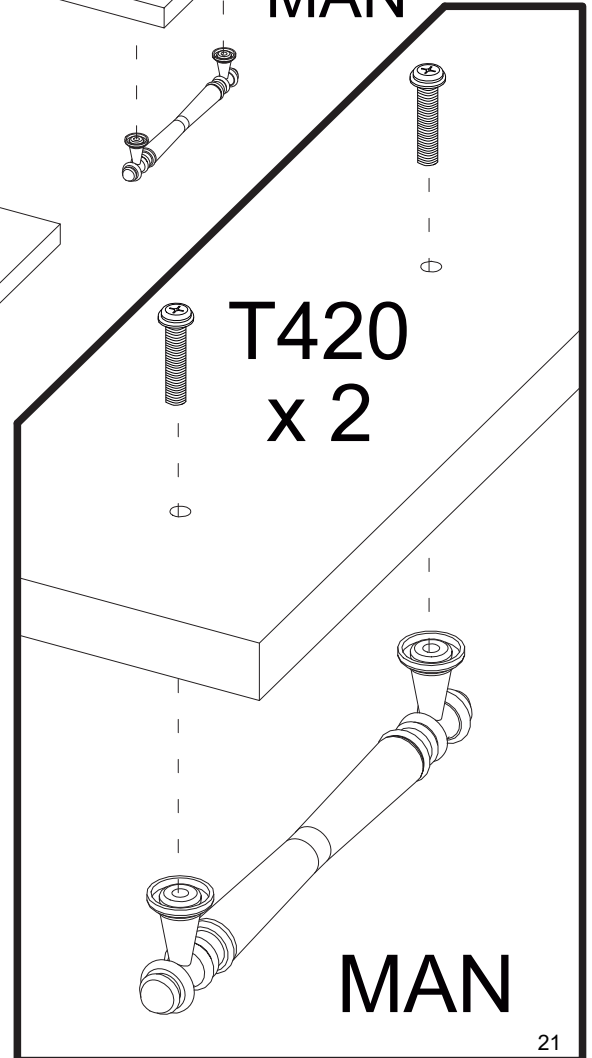
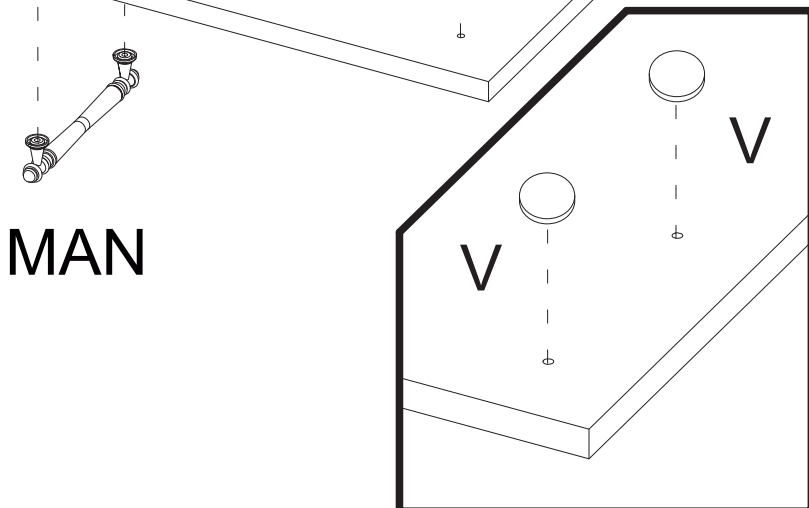
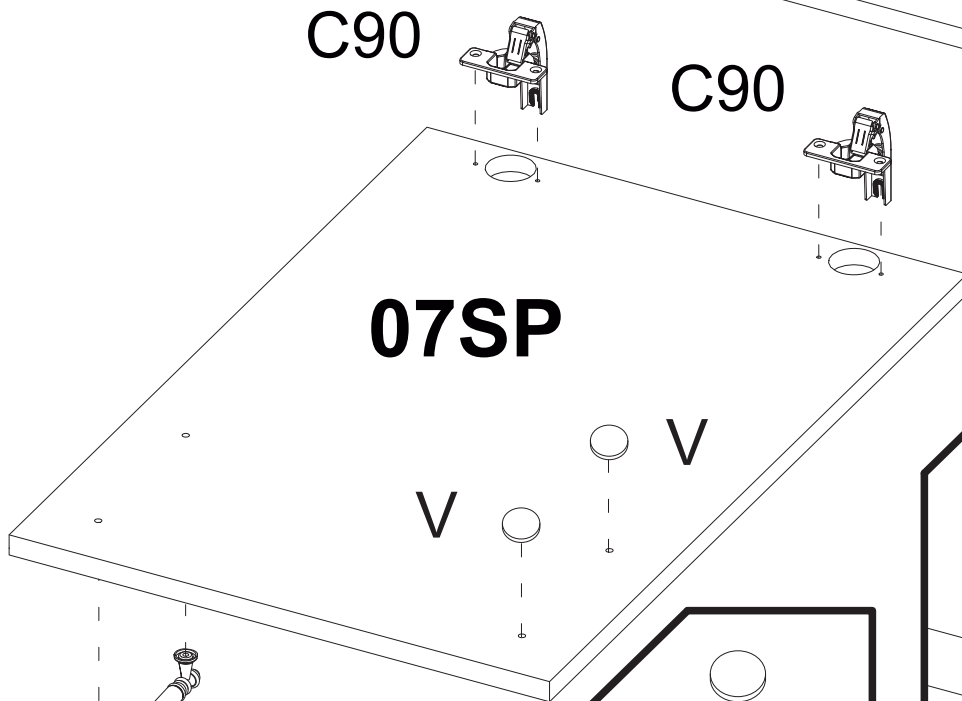
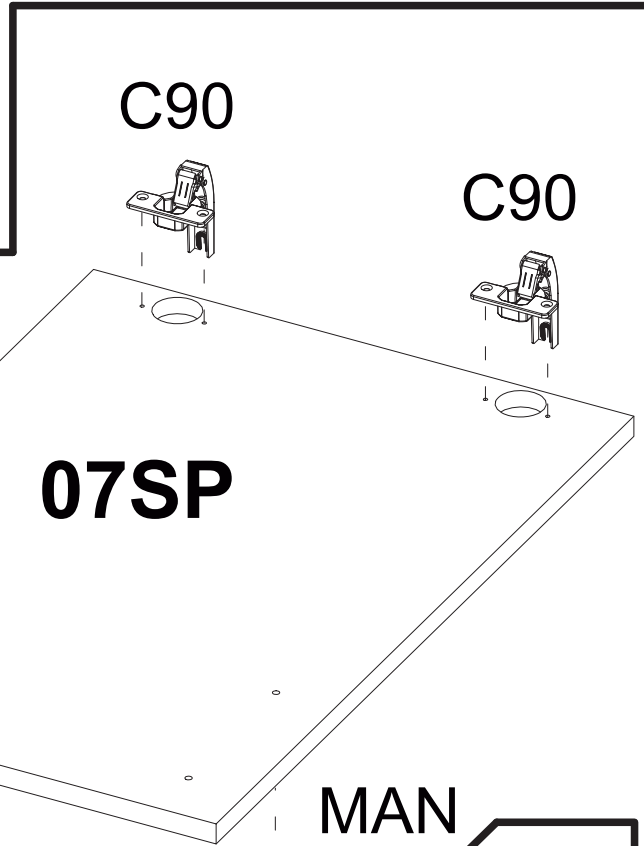
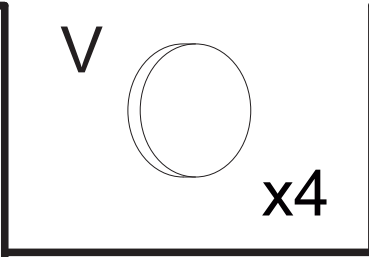
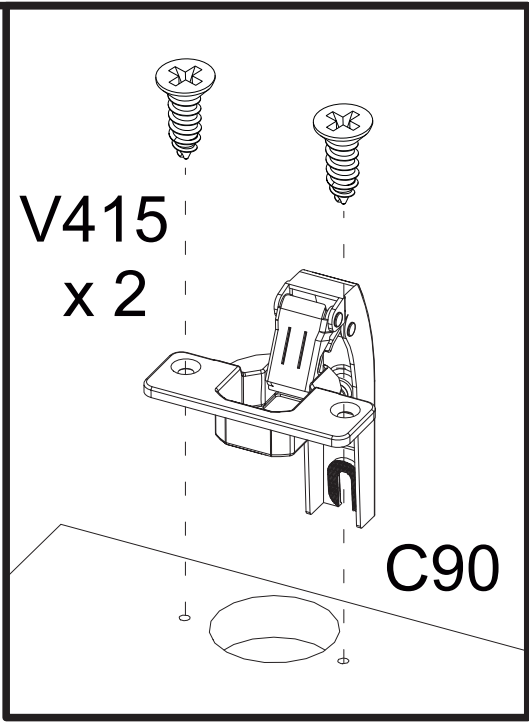

18

07SP

07SP

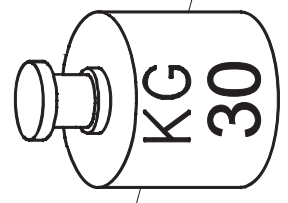
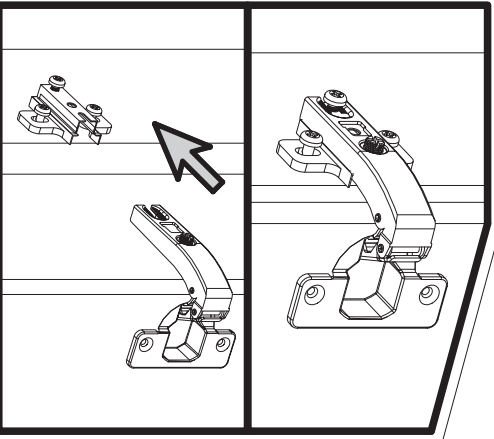

X8

G

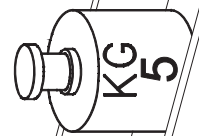
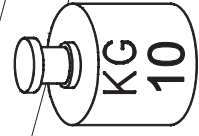
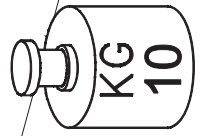
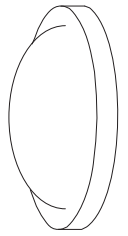

X3

G

G

G

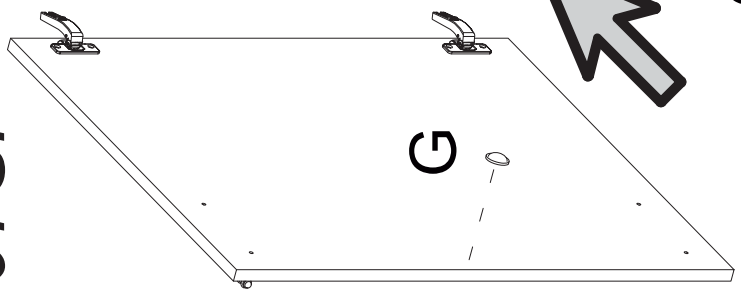

G

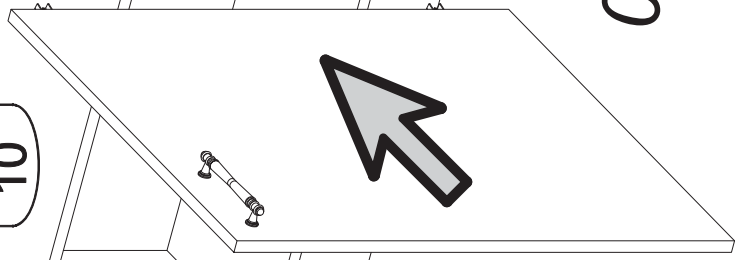

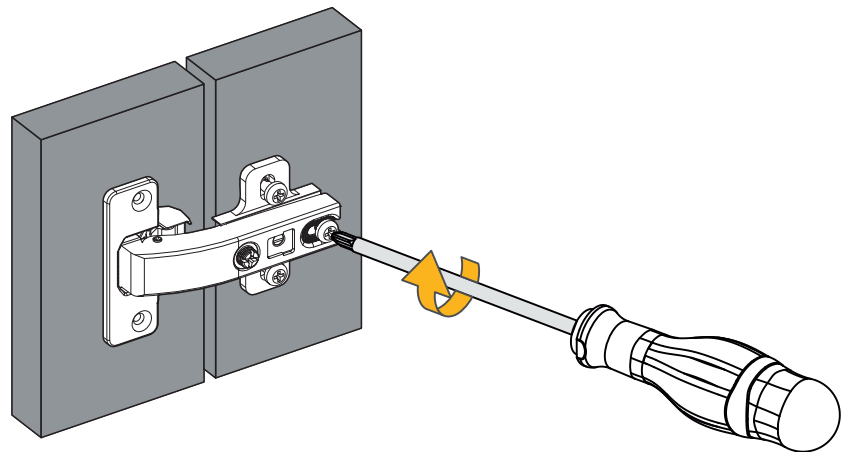
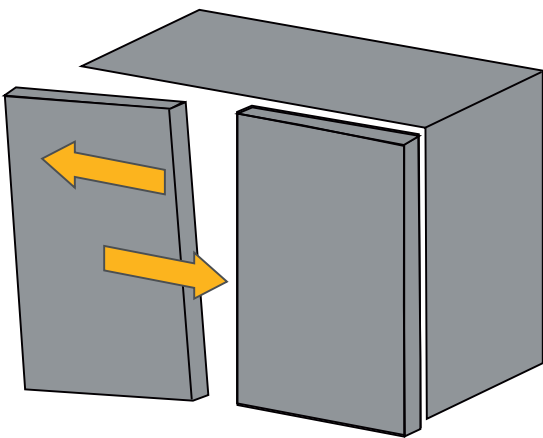
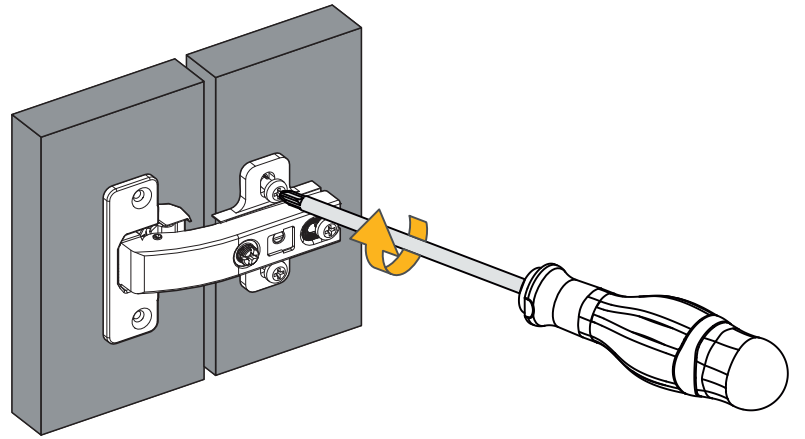
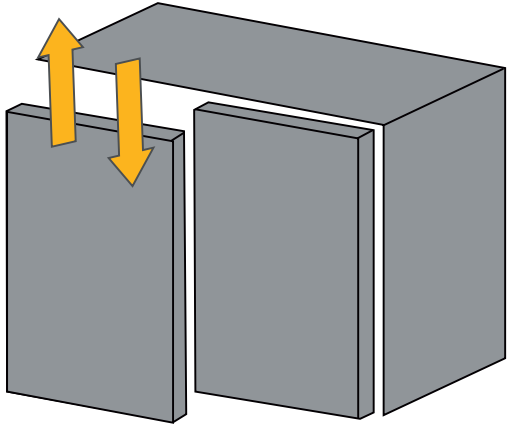
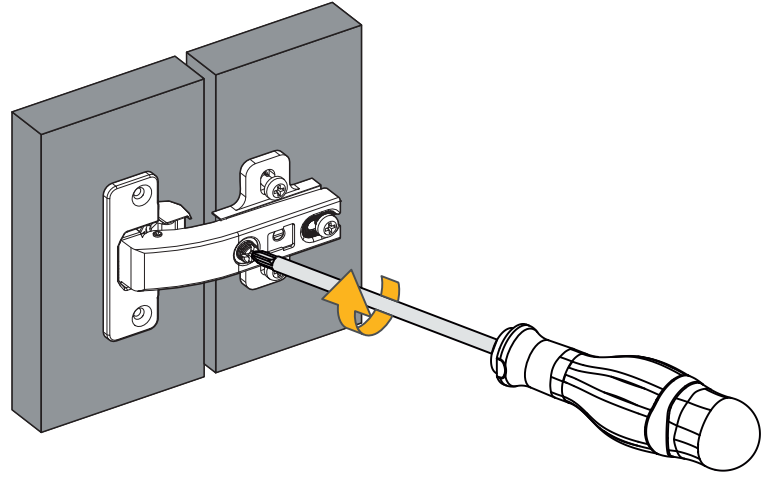
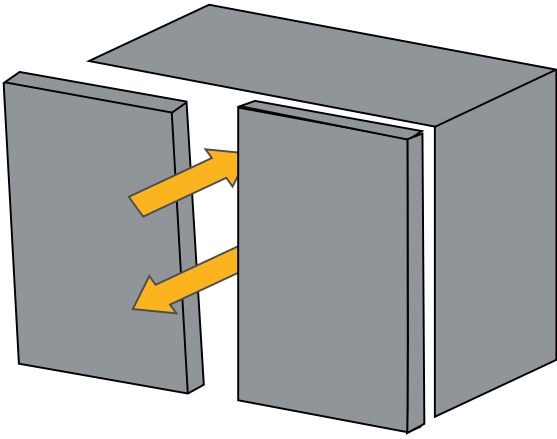

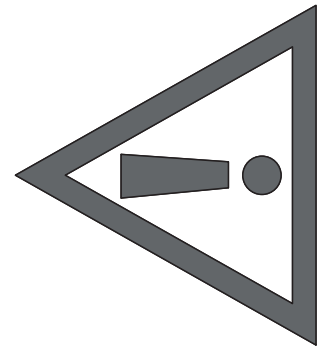
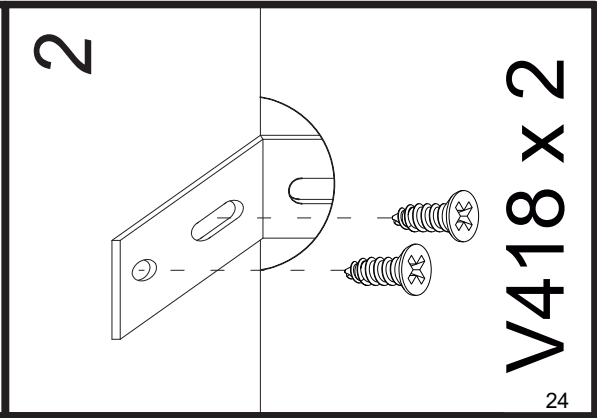
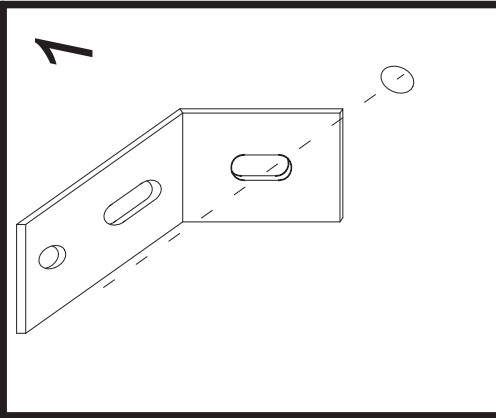
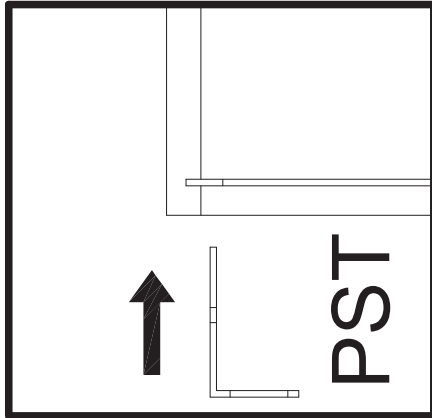

Ø8

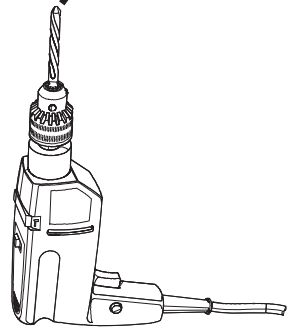

PST

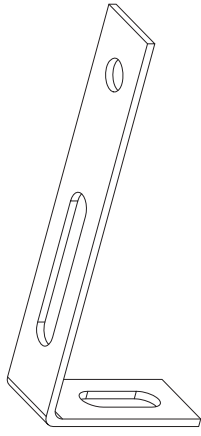

x2

V418

x4

